

Maris Water Hub

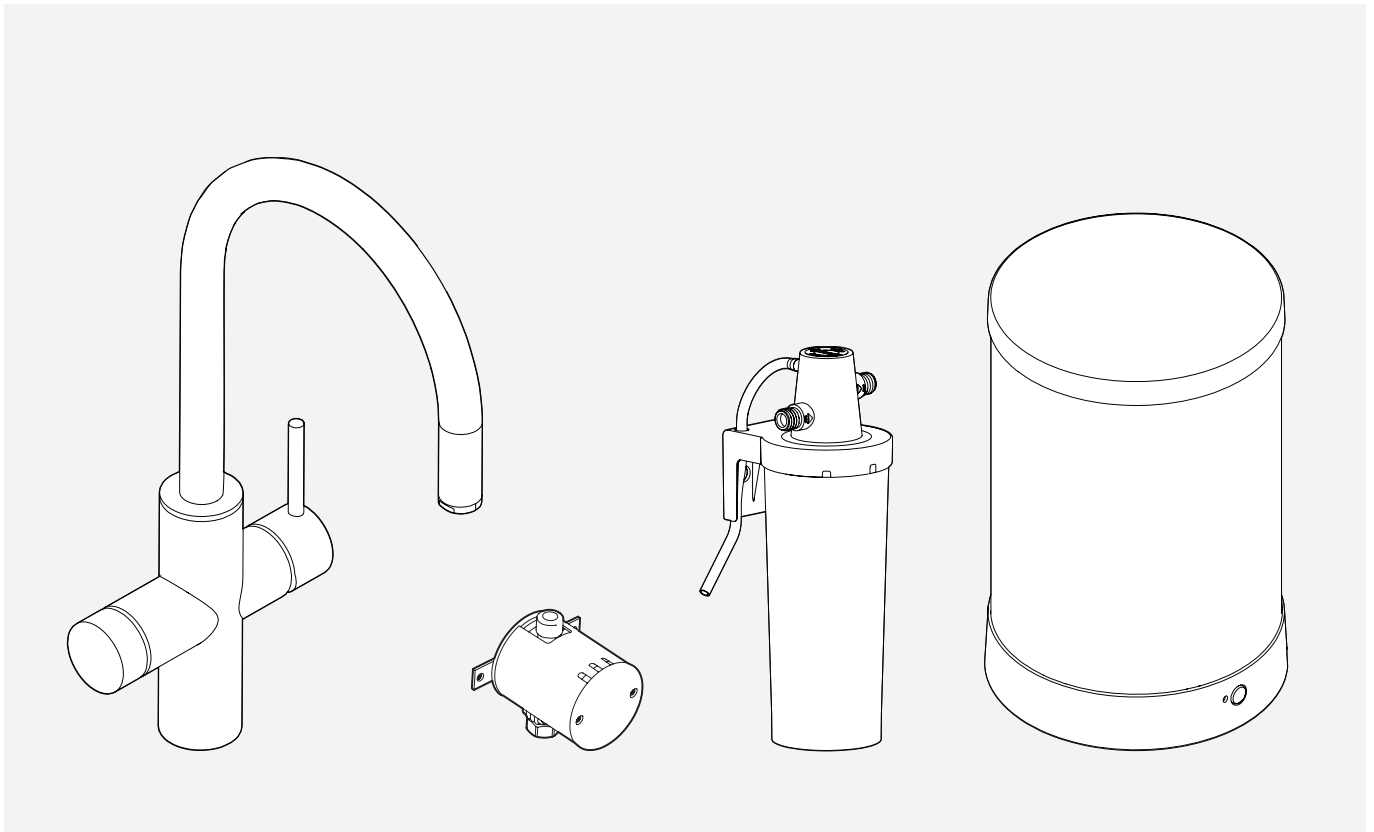

EN Installation and user manual

NL Installatie- en gebruikershandleiding

3-in-1 electronic boiling water system

3-in-1 elektronisch kokend watersysteem



Support and Warranty page

FRANKE

Table of contents

About this manual	5
Safety information	5
General	5
Tap	6
Boiler	6
Filter cartridge	6
Warranty	6
Installation instructions	7
Product information	8
System	8
3-in-1 tap electronic	8
Hydraulic box	8
Filter	9
Boiler	10
Icon legend	11
Installation	12
General starting points for installation	12
Installation steps	12
Operation	27
Operation of boiler	27
Decommissioning boiler	27
Taking boiler out of service	27
Switching on for the first time	28
Tap operation	28
Operation of mixer lever	28
Operation of electronic knob	28
Filling mode	29
Electronic knob status indicator LED	29

Filter installation/Filter replacement	29
Selection of neutral led intensity	30
Messages and malfunctions	30
Boiler messages	30
Tap messages	31
Troubleshooting	31
Maintenance	33
General maintenance	33
Replace filter	33
Descaling tap aerator	33
Disposal	34



About this manual

This manual contains important information on the safe and proper installation and commissioning of the product.

FRANKE reserves the right to make modifications to the product without prior notice. All information correct at time of issuance.

- ▶ Carefully read the user manual before using the device.

- ▶ Keep the user manual.
- ▶ Use the device described in this user manual only according to the intended use.

Symbol	Meaning
	Warning symbol. Warning against risks of injury.
	Action step. Specifies an action to be done.

Safety information

General

 Install the product as described in this manual and in accordance with the applicable installation, safety and local water supply regulations!

 Do not use the product for purposes other than those for which it is intended as described in this manual.

 The product must not be modified.

 Only insert the plug into a grounded wall socket.

 This tap may be operated by children under the age of 12 and by persons with reduced physical, sensory or mental capacities, or who lack the necessary experience or knowledge, only under supervision or after being instructed in the safe use of the product and when they are aware of the hazards that may arise from the use of the product and/or system.

 Cleaning and maintenance by the user must not be performed by children or by persons with reduced physical, sensory or mental capacities, or who lack the necessary experience or knowledge, without supervision.

 Prevent children from playing with the product and/or system.

 This product and or system is intended for use in domestic and similar environments, such as:

- Staff kitchens in stores, offices and other working environments;
- By guests in hotels, motels and other similar residential environments;
- Bed and breakfast accommodation and other similar residential environments.

 Use in other environments in consultation with the manufacturer of the product and/or system.

 If the power lead with plug is damaged, it must be replaced by the manufacturer, the manufacturer's customer service or a qualified person in order to avoid electric shock.

 If necessary, lubricate O-rings only with silicone grease.

 In order to avoid freezing, the product may only be installed in frost-free rooms.

 Safety instructions must be observed in order to avoid physical injury and/or damage to the product and/or system.

 Maintenance instructions must be observed in order to avoid damage and excessive wear.

 As a result of the ongoing improvement of our products and/or systems, illustrations in this document may differ from the appliance as delivered.

 If available, you can download the latest version of the manual via our website: www.franke.com

 Franke cannot be held responsible for costs, damage or personal injury if the product is not operated in accordance with the instructions given in this manual.

 Tap and boiler model may differ from the model illustrated in the manual.

Tap

 Avoid burns and scalding and pay attention when using hot water. The temperature of the hot water may be higher than 55°C.

 Avoid burns and scalding and pay attention when using boiling water. The temperature of the water may be higher than 100°C.

 Tiled and stone sinks will not withstand boiling water; the difference in temperature can cause these to crack. Always open the cold water tap when pouring out boiling water and preferably pour the boiling water directly into the drain.

Boiler

 Before commissioning, ensure that the boiler is filled with water.

 Never pick up or carry the boiler with the hoses or the mains lead.

 The appliance must be connected always with the cold water supply.

 Before installation of the boiler make sure the pressure relieve valve outlet is 8 cm above the connection of the waste pipe.

 The drain hose must be connected with a continuous downwards gradient and a siphon must be made, therefore please note you may need to cut the drain hose.

Filter cartridge

 The use of a Franke filter is mandatory to protect the product against lime scale deposits. It is mandatory to change the filter based on the water hardness table.

 After storage at a temperature of 0°C, the filter must first be stored for 24 hours at room temperature before it is installed.

 The filter cartridge must not be opened or damaged.

 The filter cartridge and the system must be intensively flushed after a prolonged standstill period and/or during maintenance work (2 liters of flushing water after 1 week standstill; 10 liters of flushing water after 4 weeks' standstill).

 The filter cartridge must be replaced if, after commissioning, it has not been in operation for 3 months.

Warranty

Scan the QR code to reach the Warranty guidelines:



Installation instructions

 **Caution:** Never use serrated tools in order to avoid damage. Where necessary, always use the appropriate tools for tightening the coupling.

- ▶ Minimum bending radius after installation.

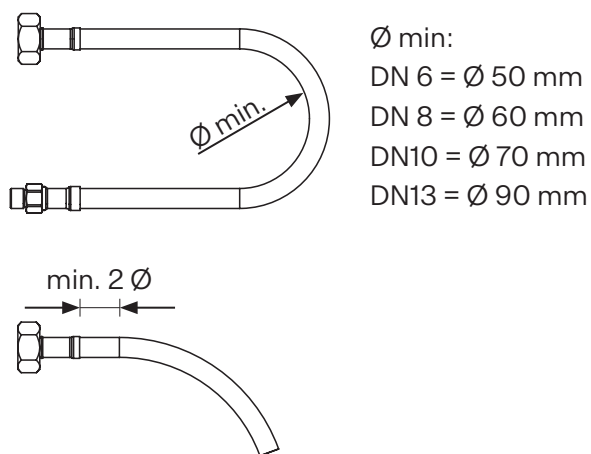

- ▶ Without bends after installation.

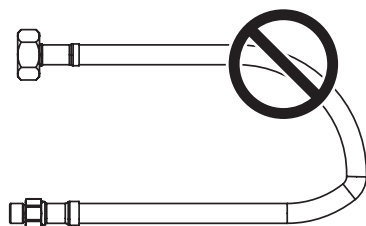

- ▶ Without bend immediately after connection.



- ▶ Without tension after installation.



- ▶ Without torsion after installation.



Product information

System

Water supply pressure (min.)	100 kPa/14.5 psi/1 bar
Water supply pressure (max.)	500 kPa/72.5 psi/5 bar
Flow rate boiling water	2 - 4 l/min * 2.5 bar
Flow rate cold water	5 - 9 l/min *
Flow rate hot water	5 - 9 l/min *

* The flow rate varies, depending on the water supply pressure and the type of tap.

3-in-1 tap electronic

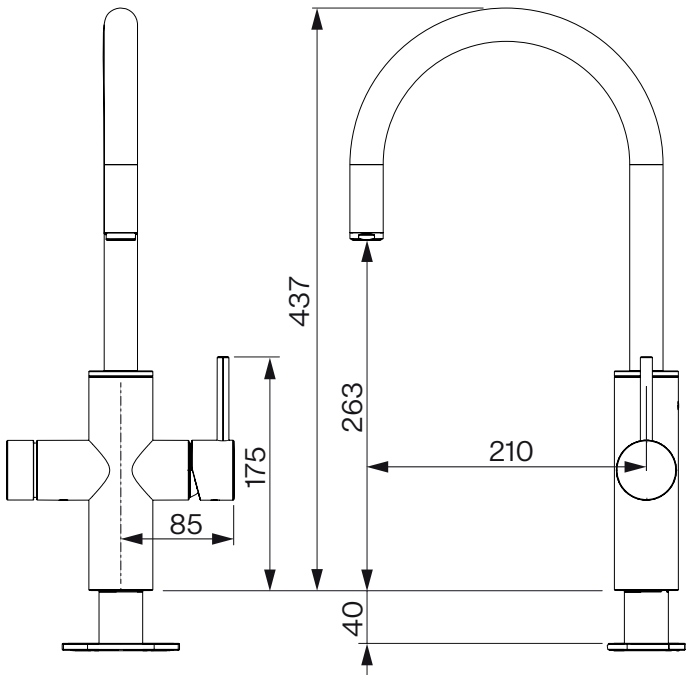

Hydraulic box

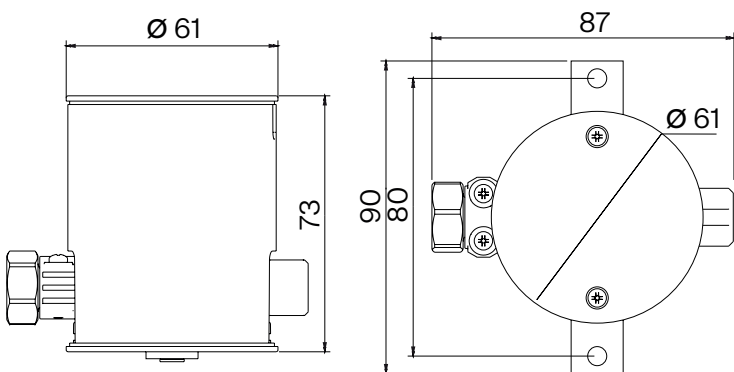

Filter

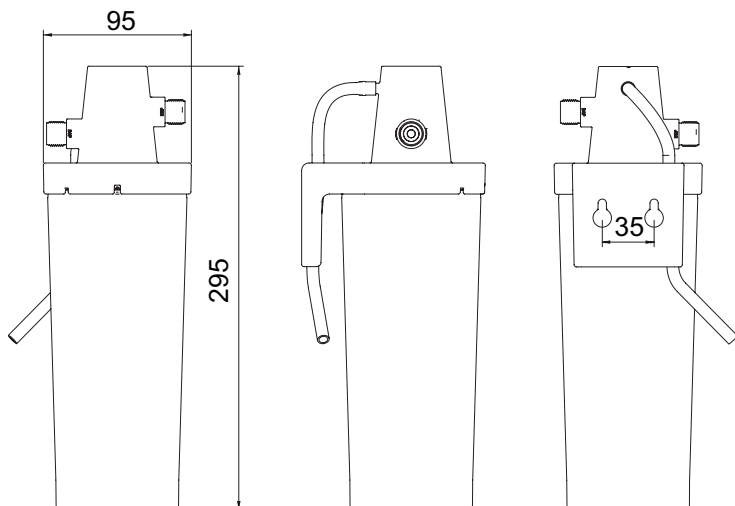

Filter type	Protection Filter
Diameter	95 mm
Height incl. Filter head	295 mm
Filter head	Bayonet / Separate part

Filter lifetime

Water hardness	<10°dH = 12 months
	10-15°dH = 10 months
	15-20°dH = 8 months
	>20°dH = 6 months

Filter disposal residual waste

Decarbonization	Yes
Odors	Yes
Chlorine	Yes
Particle	Yes
Microplastics	Yes

 The use of a Franke filter is mandatory to protect the product against lime scale deposits. It is mandatory to change the filter based on the water hardness table.

Boiler

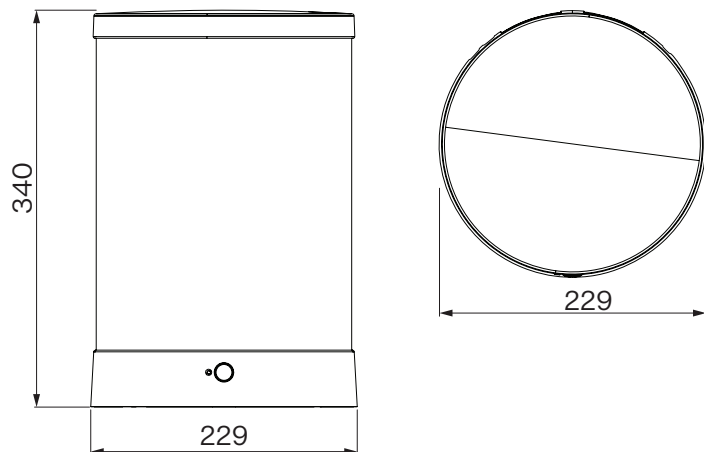

Boiler	4 liters
Dimensions [H x W]	340 x 229 mm
Net weight	4.5 kg
Contents	4 l
Voltage	230 VAC
Power	2100 W (+5%/-10%)
Load	9.2 A
Standby mode max.	14 W
IP classification	IPX4
Storage temperature	<105°C
Heating time [ΔT 100 K]	15 min
Operating pressure (max.)	800 kPa / 116 psi / 8 bar
Operating temperature:	0-40°C
Power supply EU:	Type E+F CEE 7/7 Schuko
Power supply UK:	Type G/ BS 1363 British 3 Pins
Declared load profile and typical usage	XXS
Water heating energy efficiency class	A
Water heating energy efficiency	35.15 %
Annual electricity consumption	523 kWh
Thermostat temperature setting	103°C























Water quality requirements

pH value 7 - 9.5



Warning: Only vertical installation of the boiler is possible (on/off knob on the bottom).

Icon legend

	Product information		Inspect
	Scope of Delivery		Determine position
	Montage		Open
	Tooling Equipment		Close
	Do not use tools		Discard
	Measure		Cold water
	Drill		Warm water
	Screw		Boiling water
	Spanner		Do not / Forbidden result
	Cut		Do, OK! / Result
	Tighten finger-tight		url / video link
	Warning Sign / Caution / Hazard		

Installation

General starting points for installation

Perform the following steps before starting installation.

1. Stop valves must already be installed.
2. If the water pressure is above the 5 bar, use a pressure reducing valve (3 bar).
3. Close the stop valves.
4. In existing installations, remove the tap, hoses and boiler if still in place.
5. Mark the existing cold and hot water connection.
6. There must be two wall plug sockets available for connection.



Install the pressure relief valve as high as possible in the kitchen cabinet.

Installation steps

1. Installing 3-in-1 tap (see page 14)
2. Installing filter (see pages 15)
3. Installing pressure relieve valve (see page 16)
4. Connecting drain hose (see page 17)
5. Installing boiler (see page 17)
6. Installing Hydraulic Box (see page 17)
7. Connecting Hydraulic Box (see page 18)
8. Connecting tap (see page 18)
9. Activating Hydraulic Box (see page 19)
10. Flushing boiler (see page 19)
11. Activating boiler (see page 19)
12. Installing with WWS (see pages 20, 21, 22 and 23)
13. Installing with Bypass (see pages 24, 25 and 26)
14. Commissioning (see page 27)

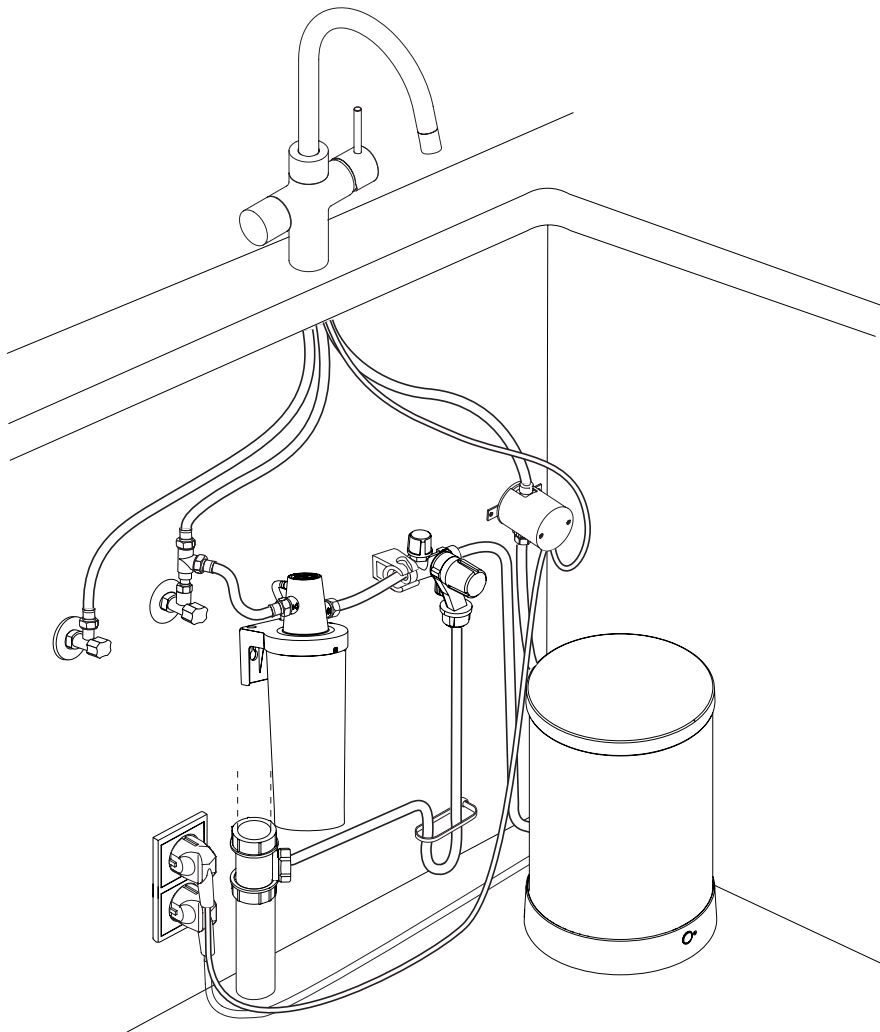
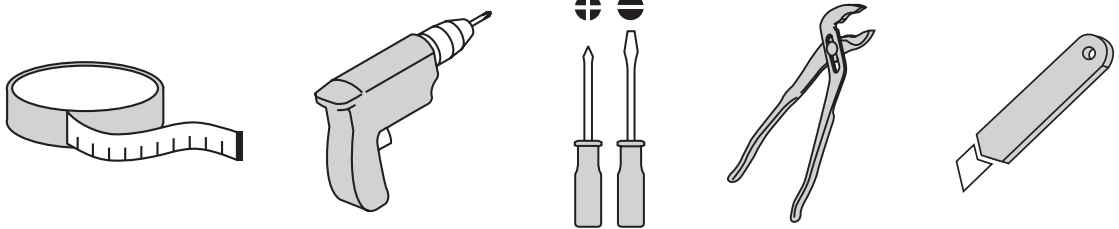
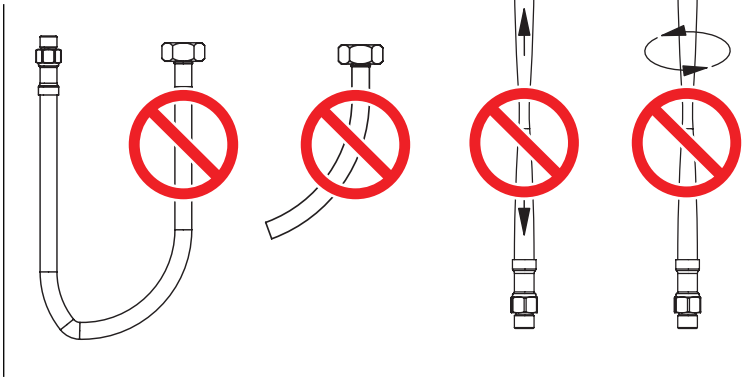

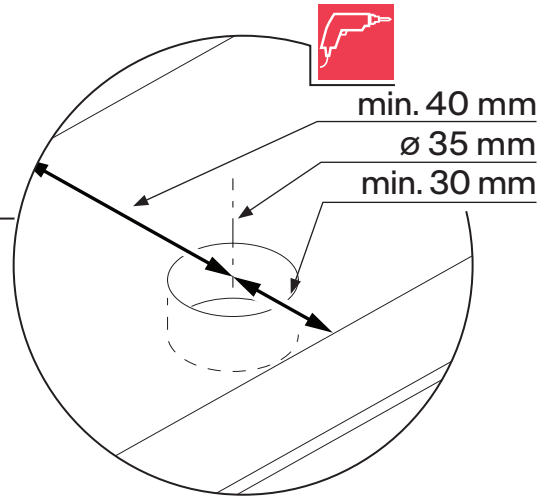
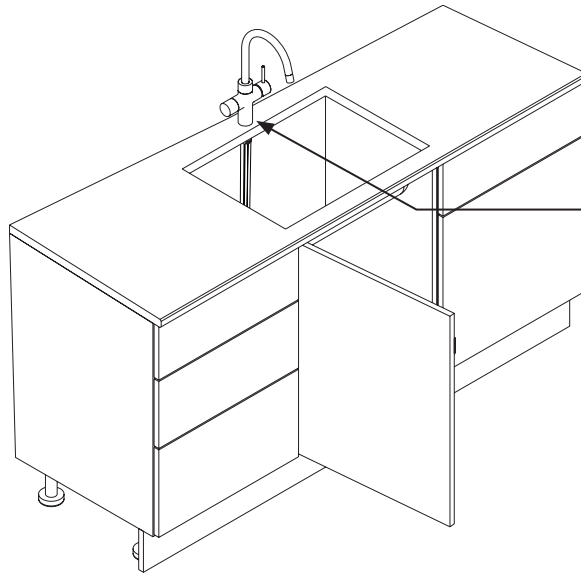

1

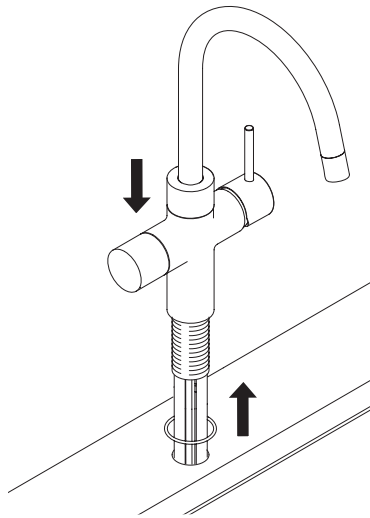

2

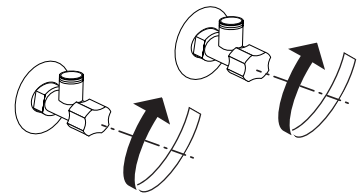
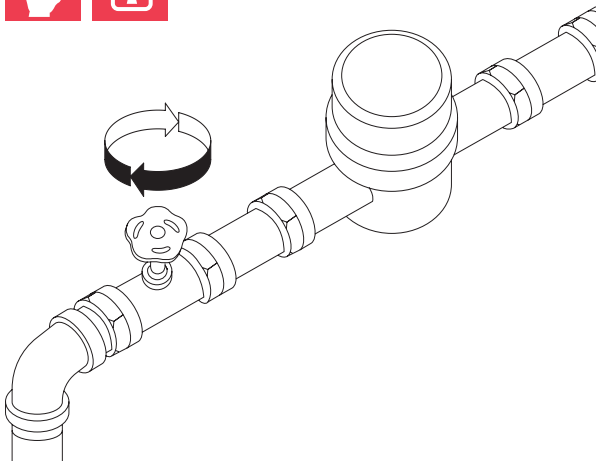
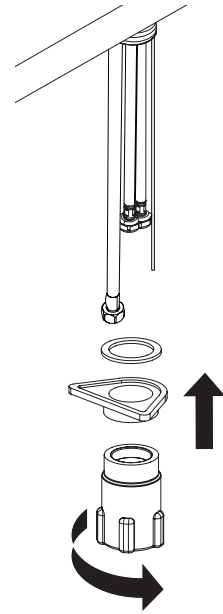

1

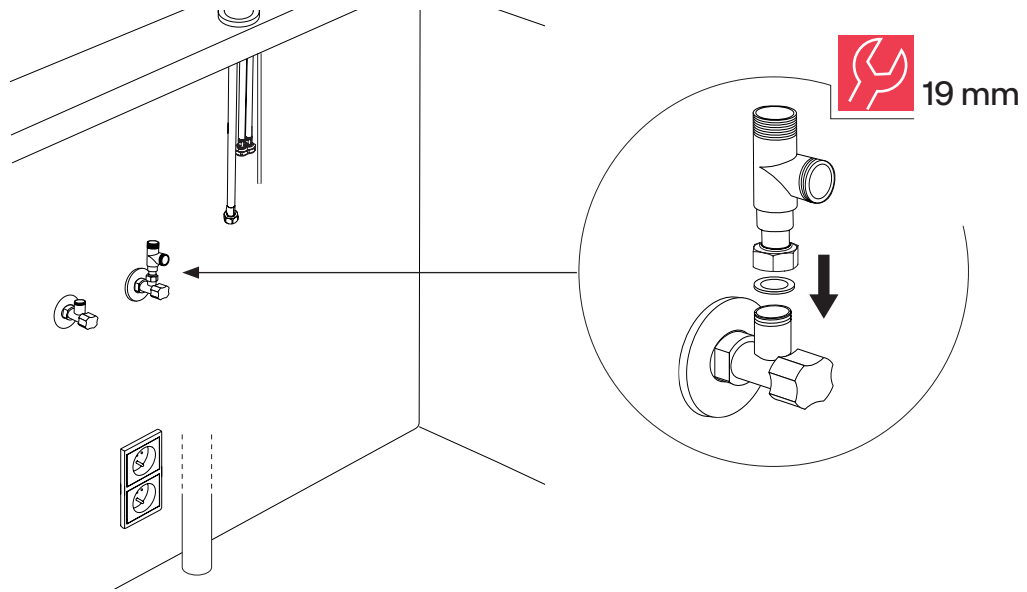

2

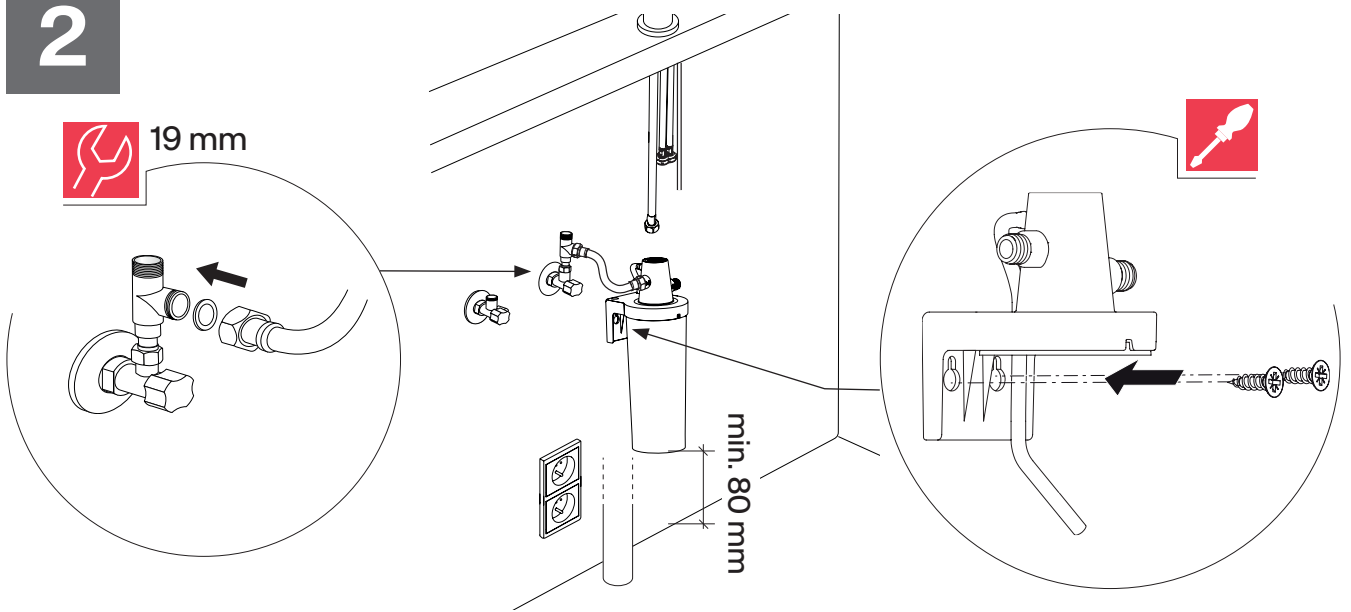

i

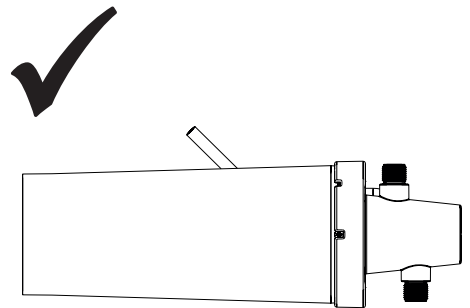
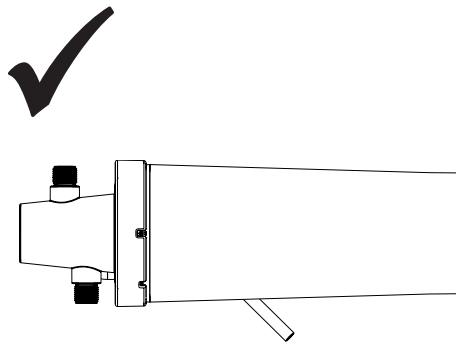
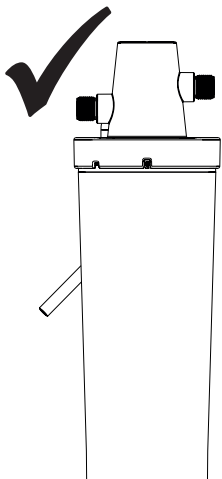

3

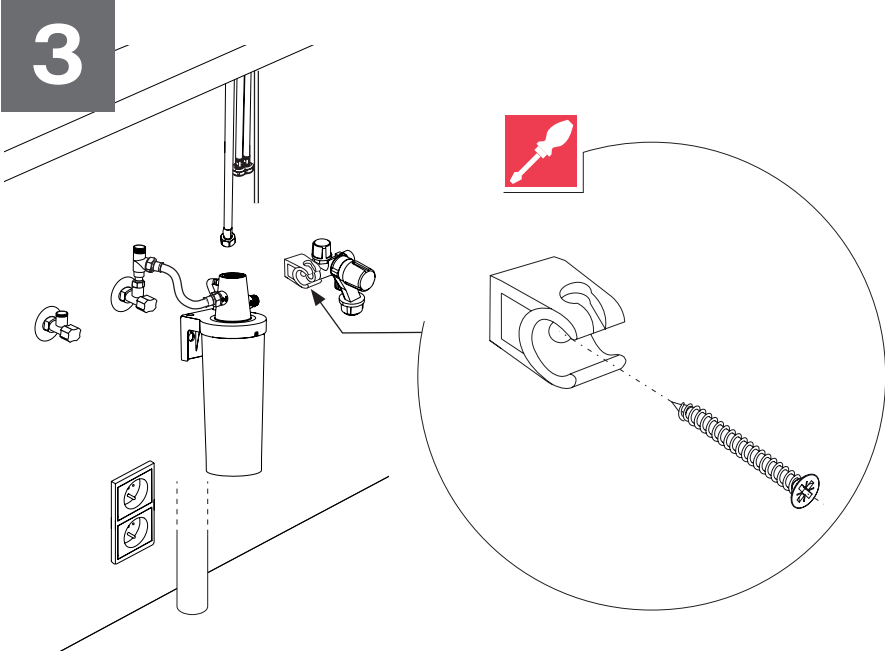

4

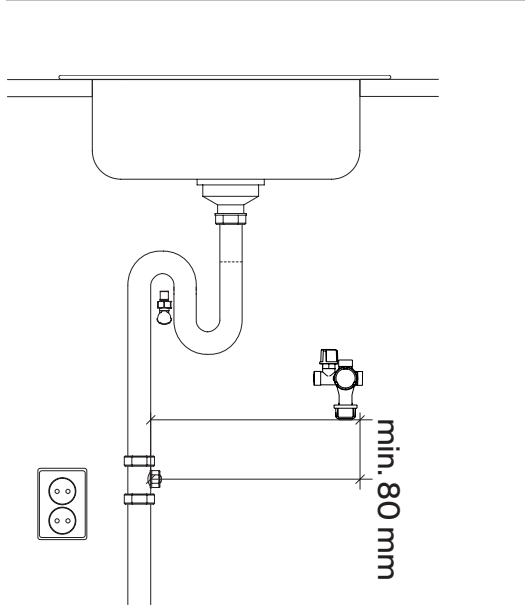
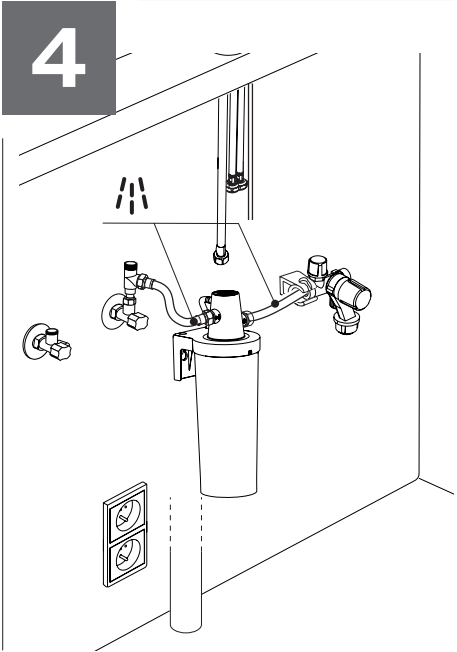

5

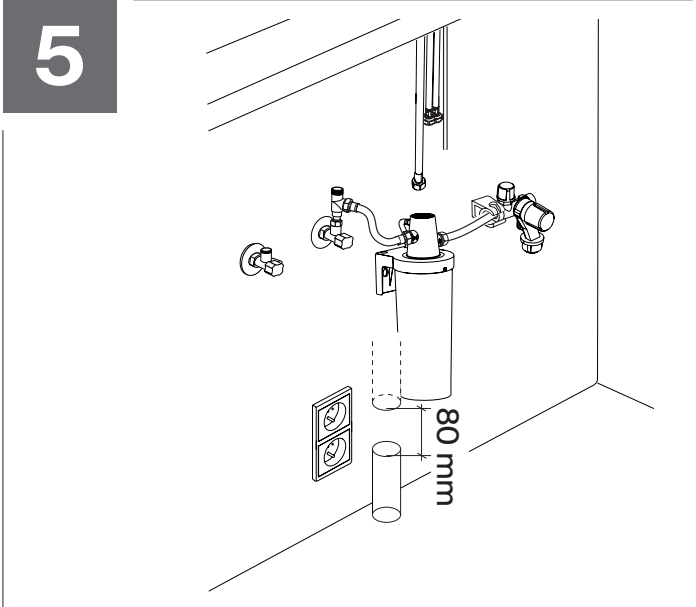

6

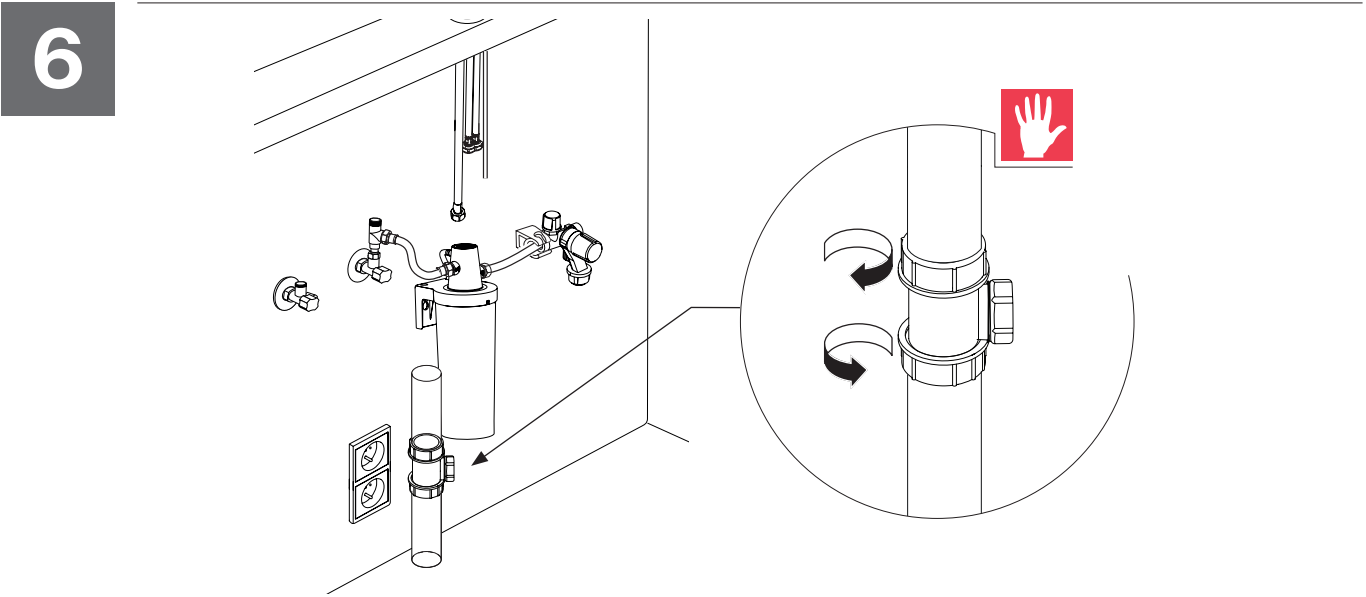

7

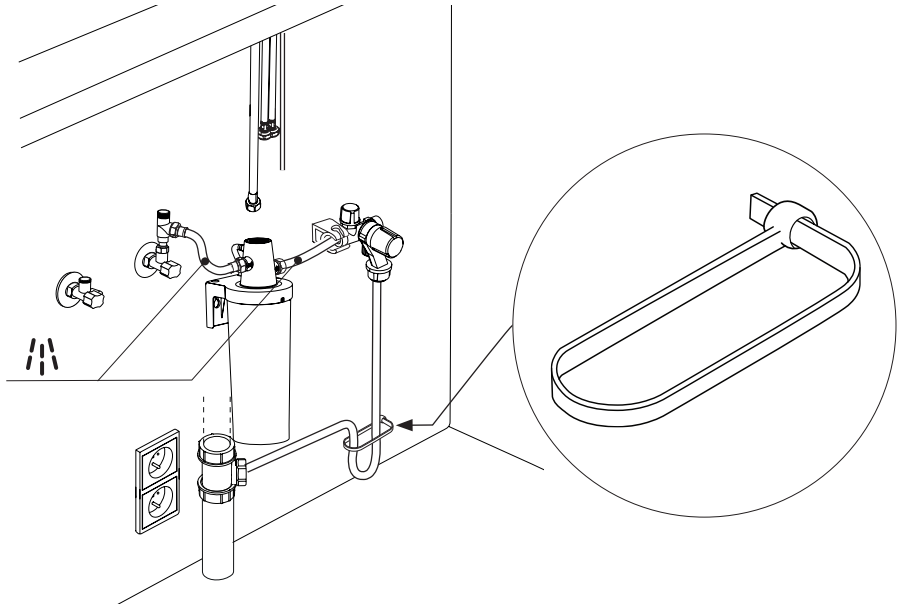

8

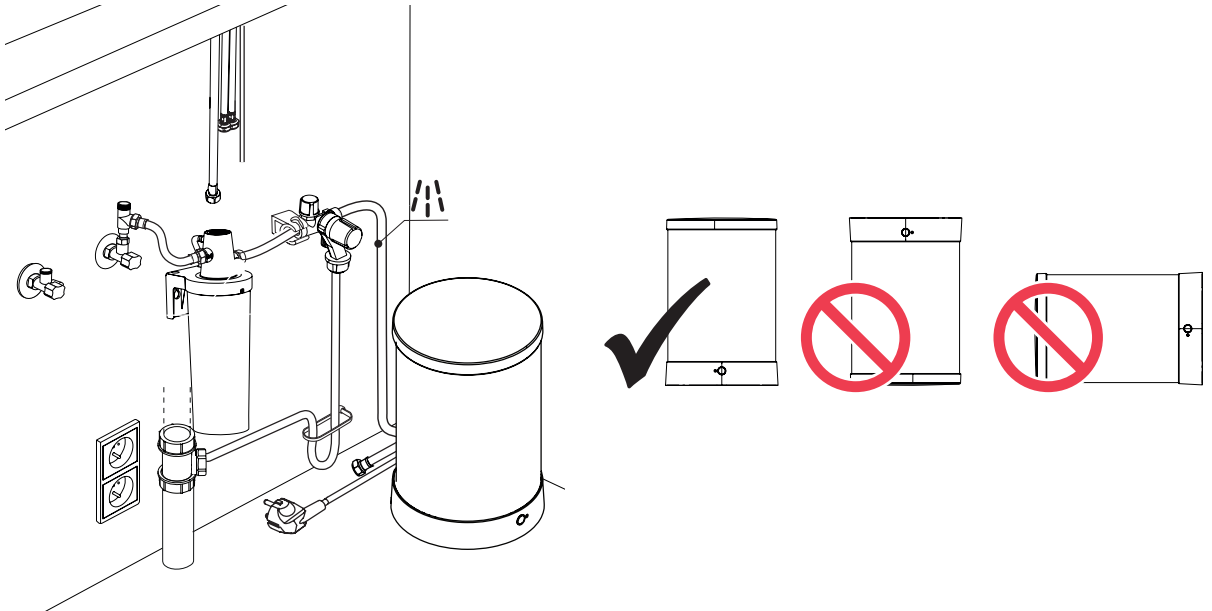

9

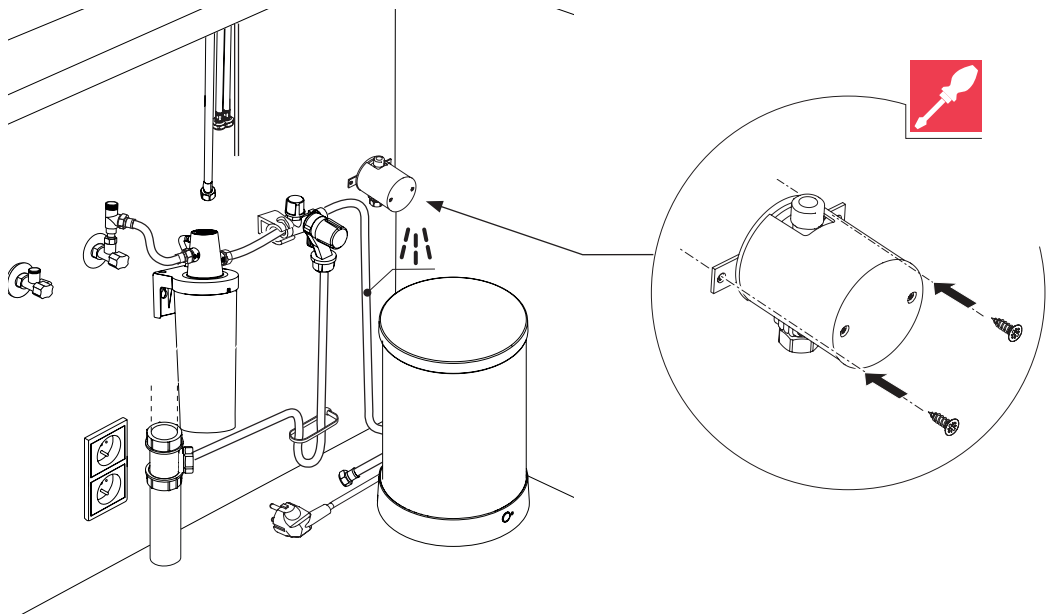

10

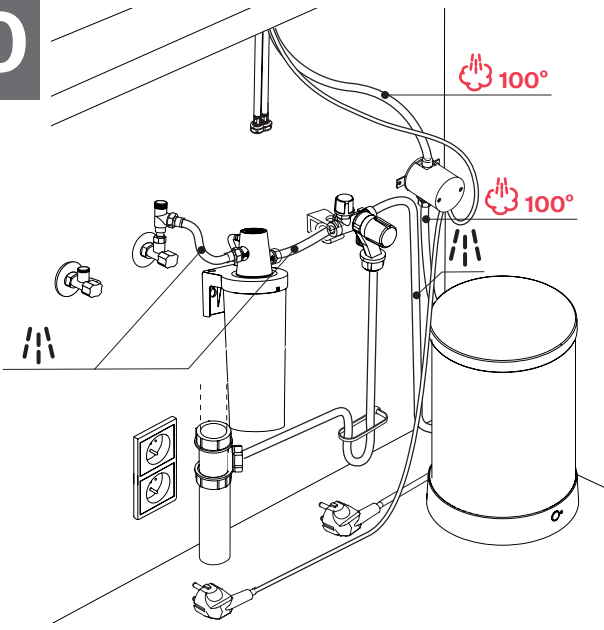

11

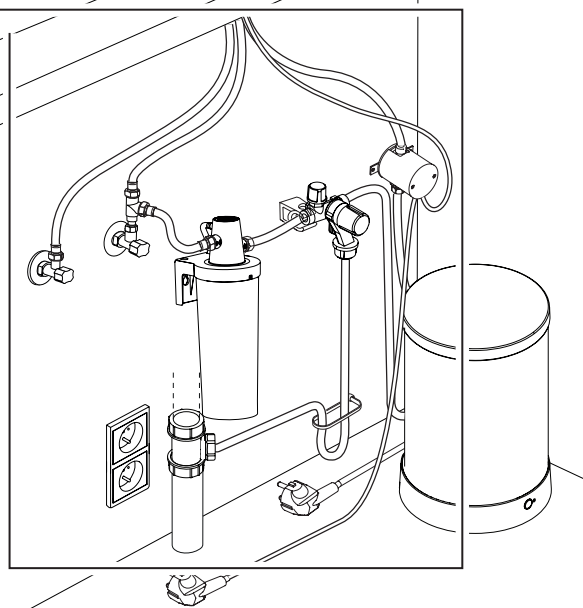
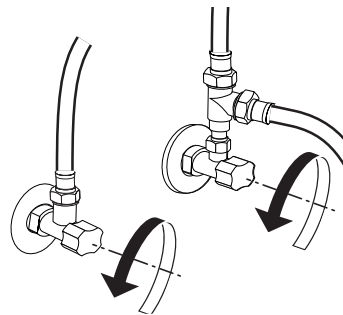
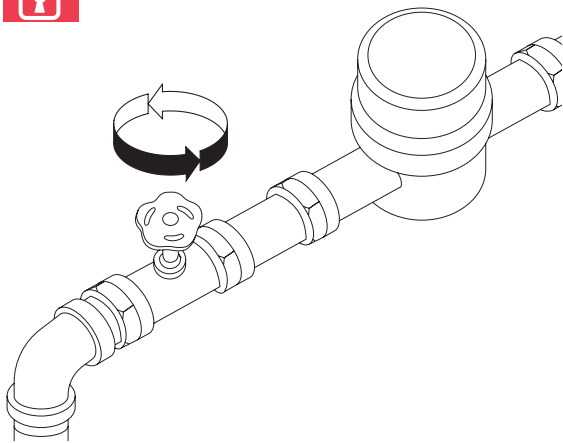
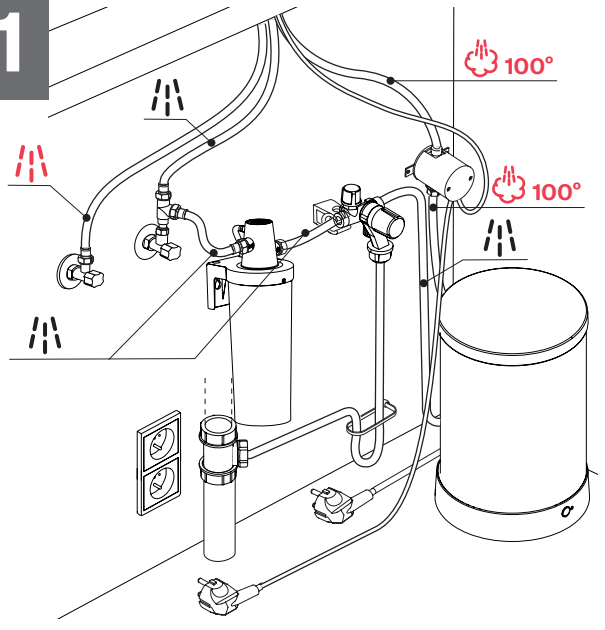

12

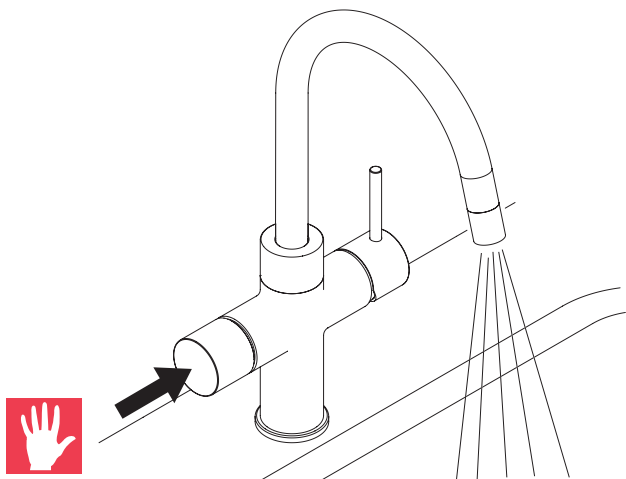
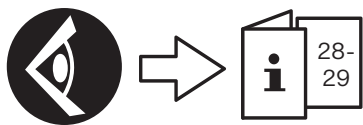
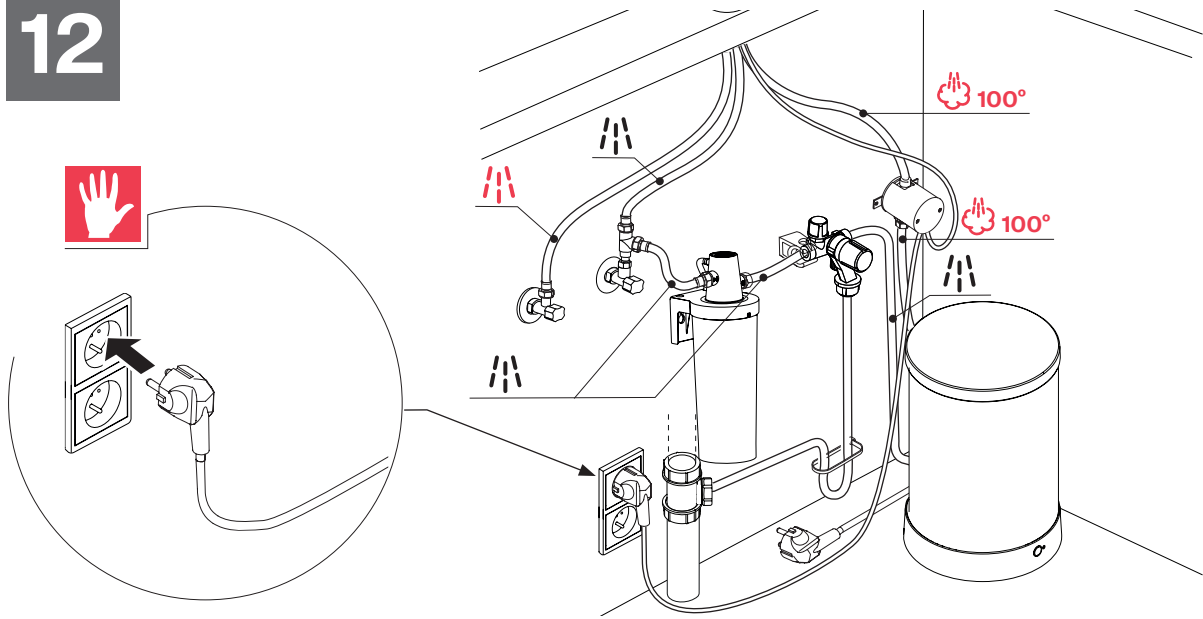

13

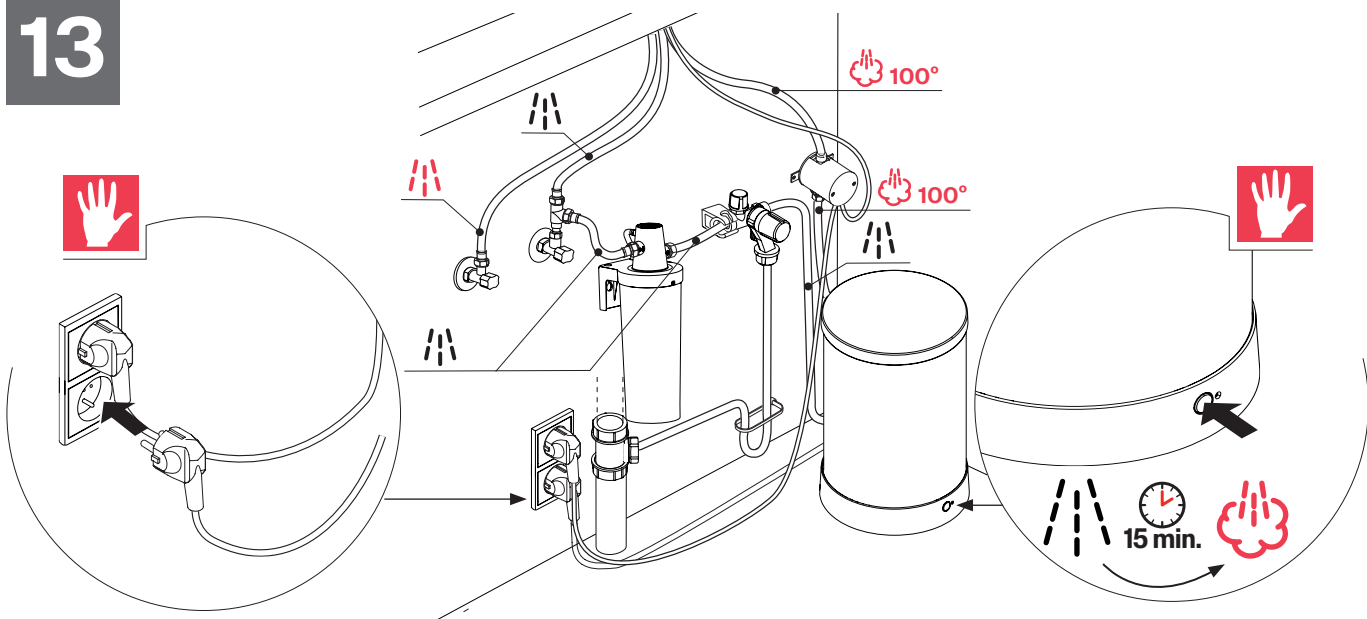



Not included

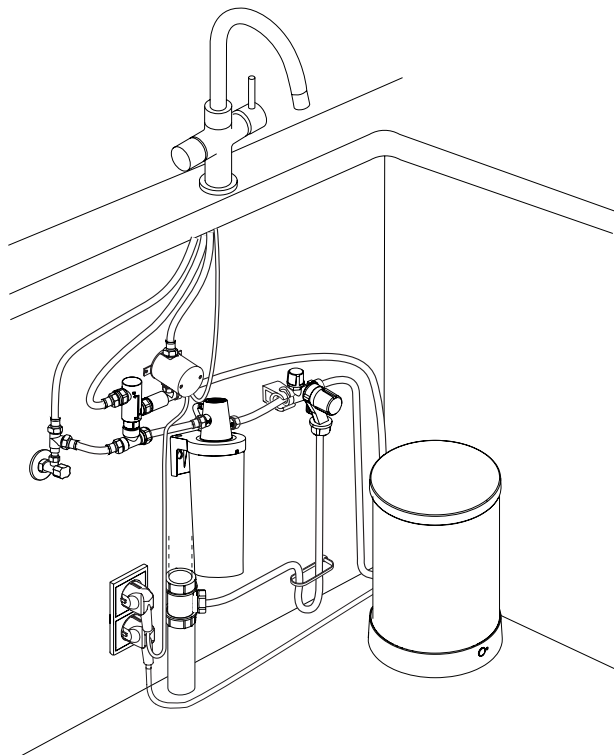
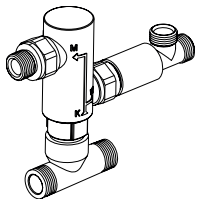

1

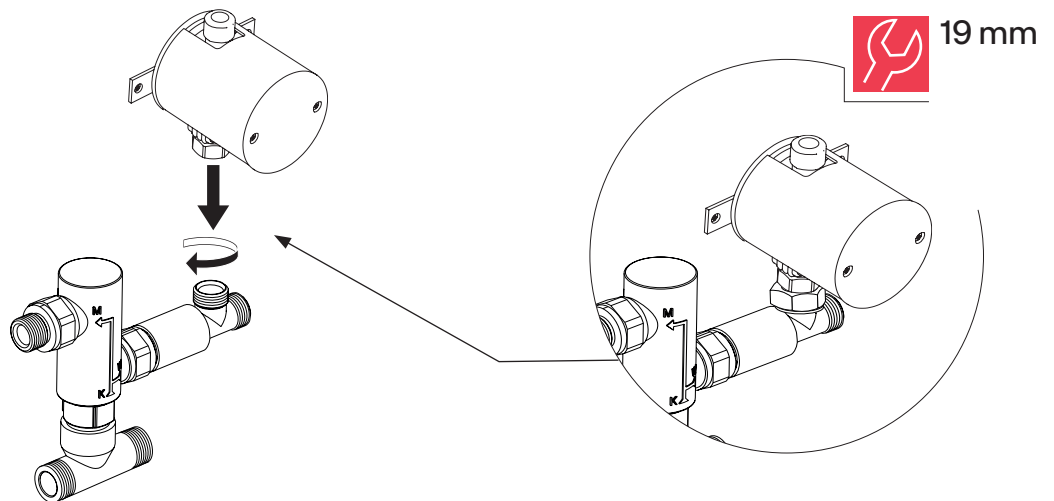

2

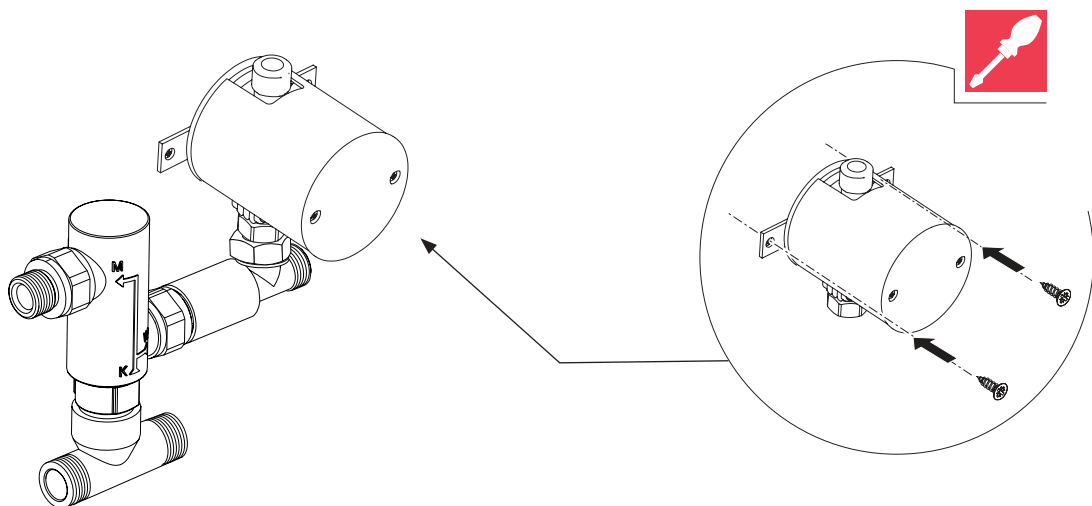

3

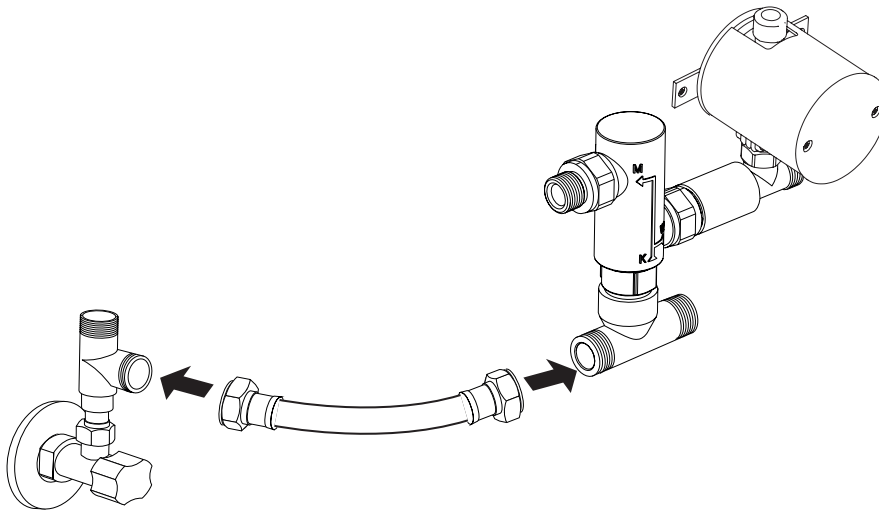

4

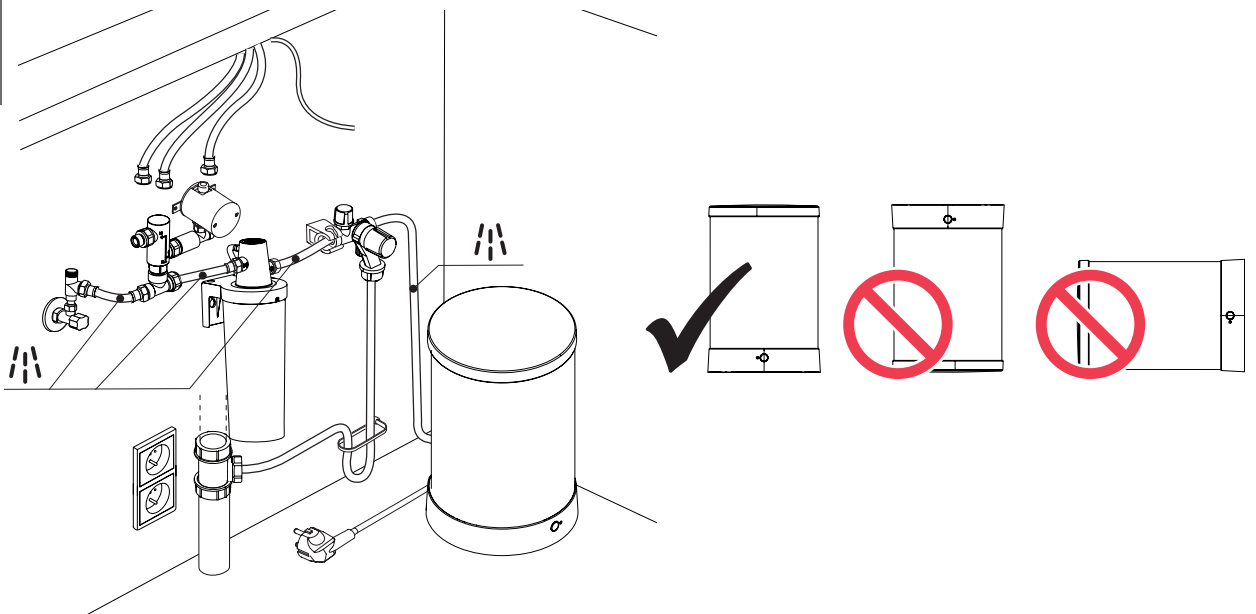

5

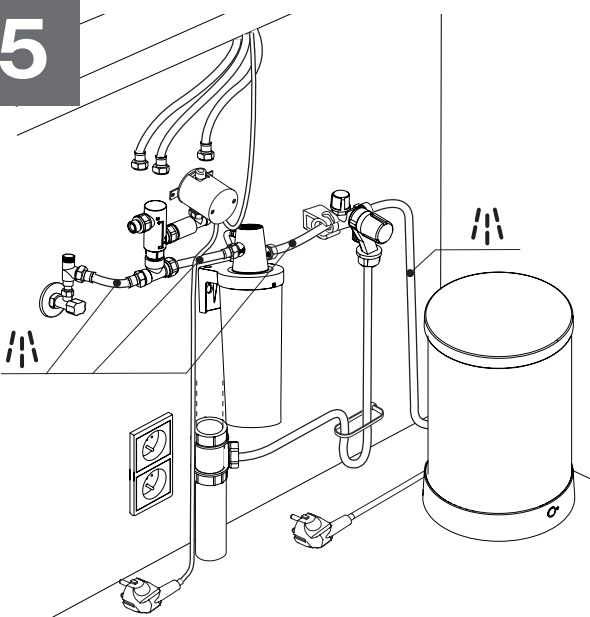

6

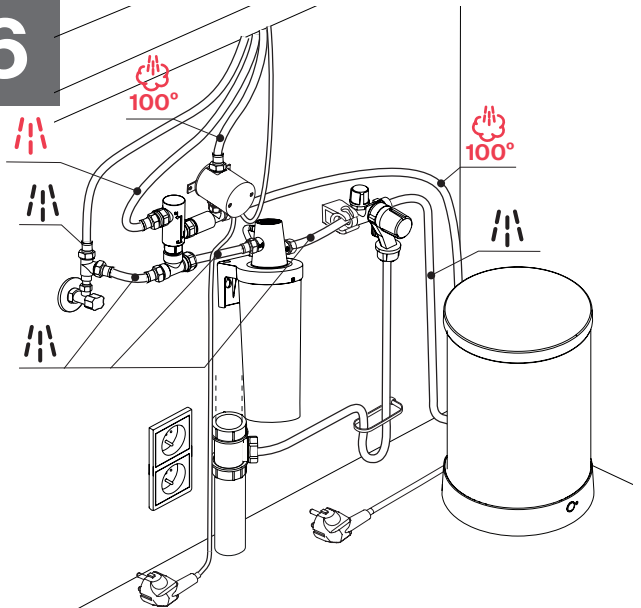

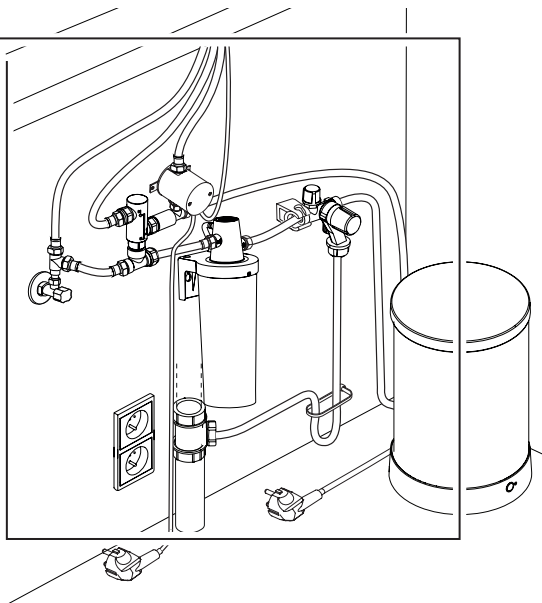
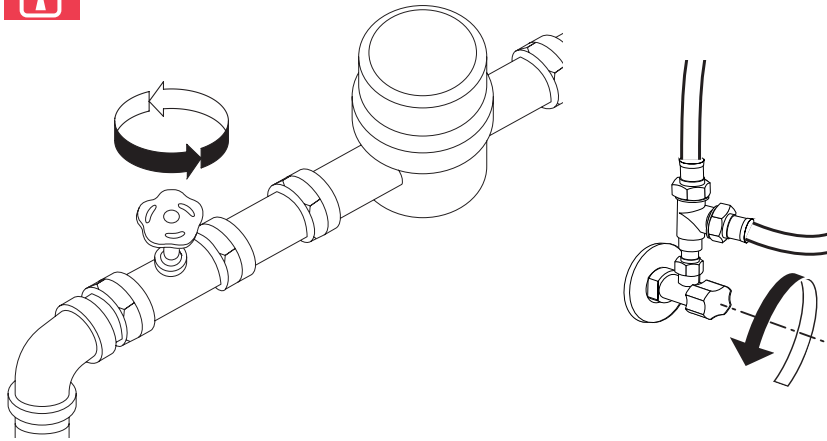

7

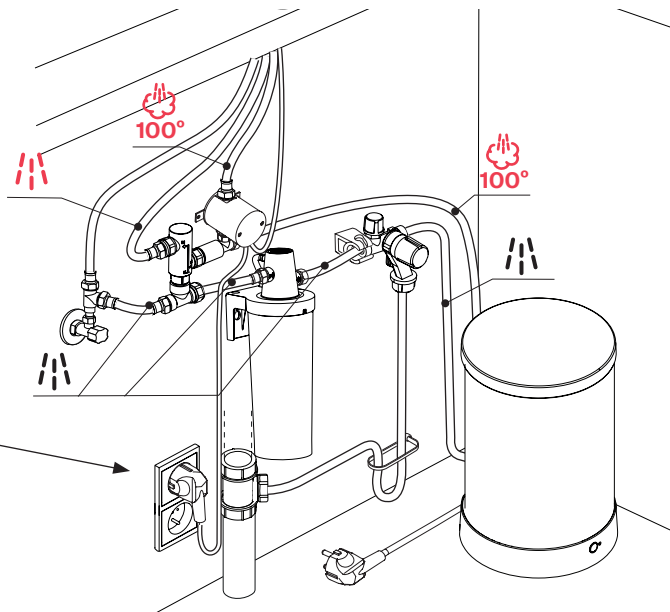
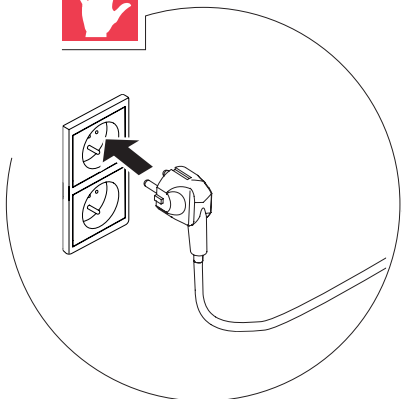

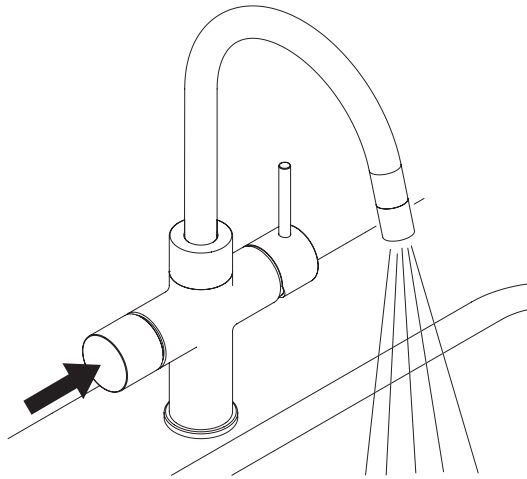

8

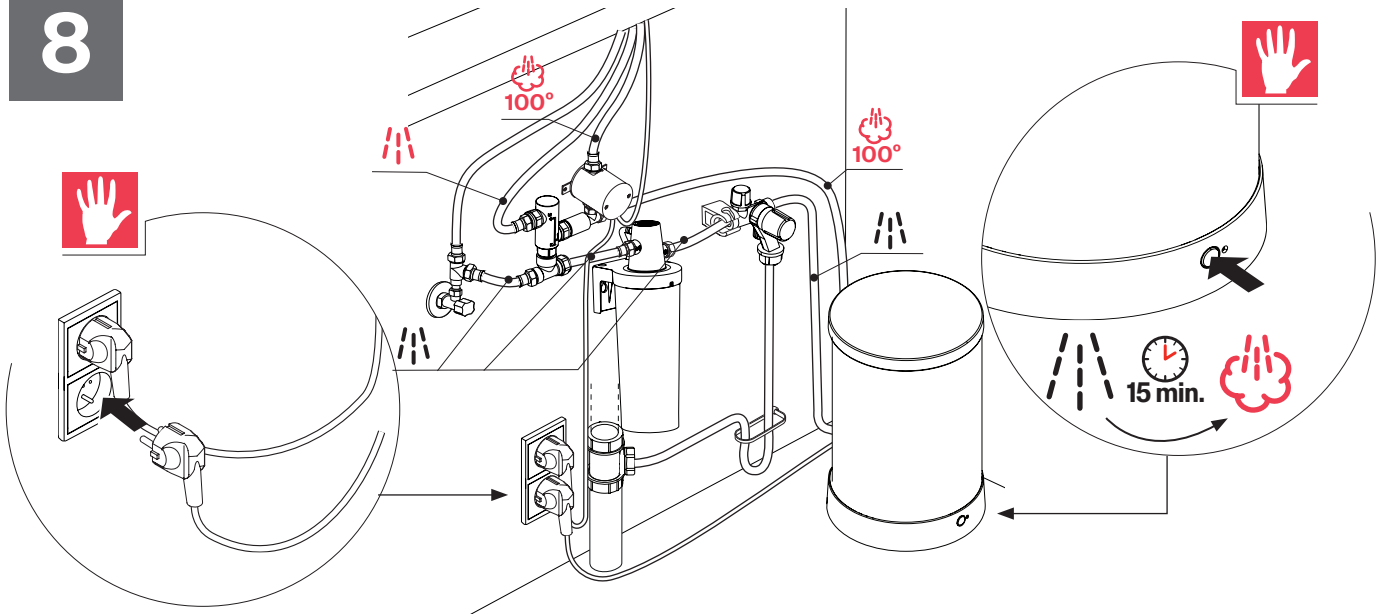



B

Not included

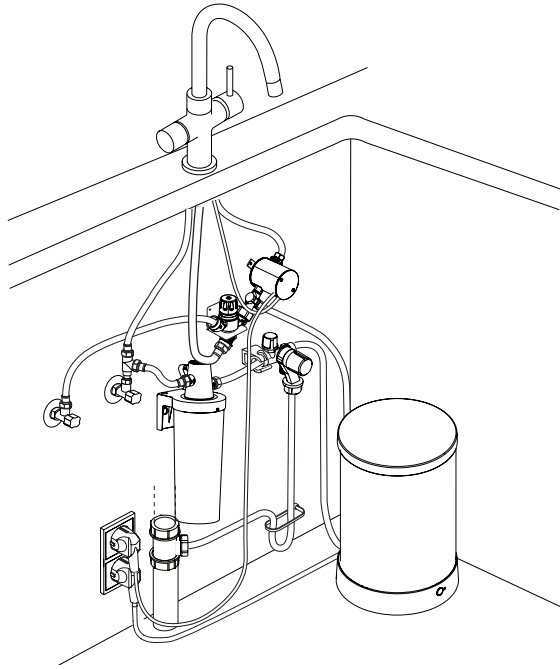
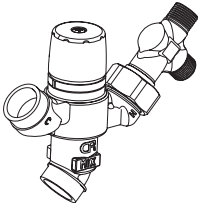

1

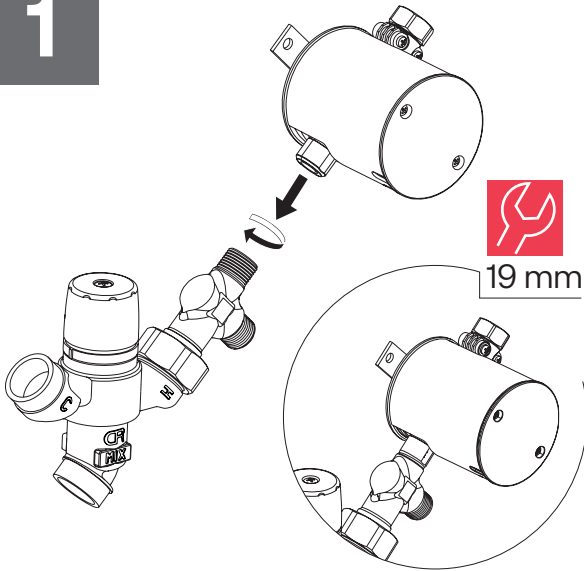

2

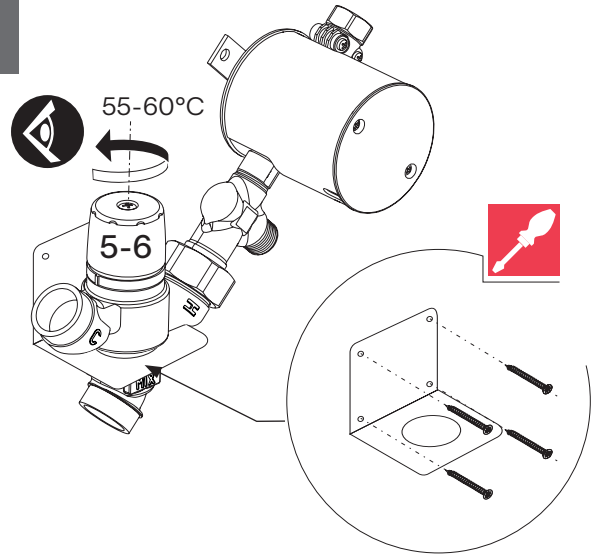

3

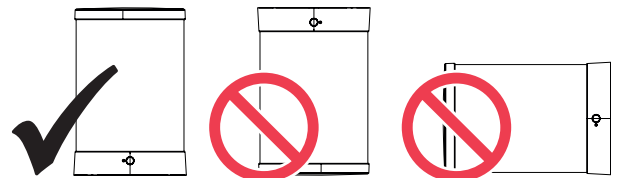
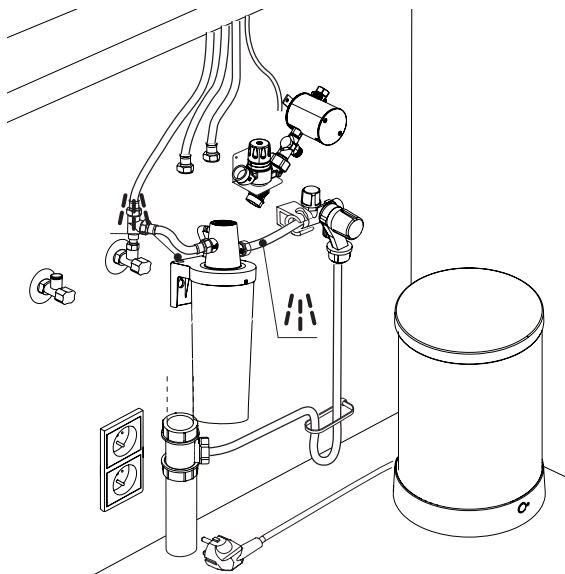

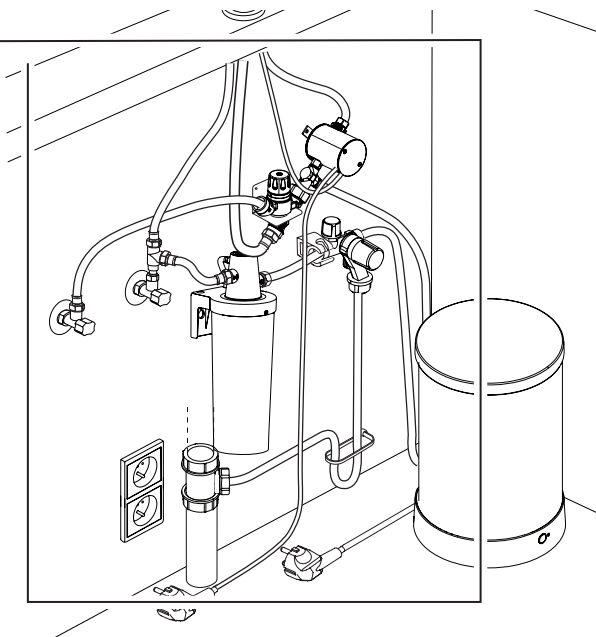
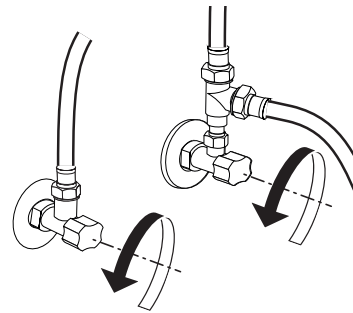
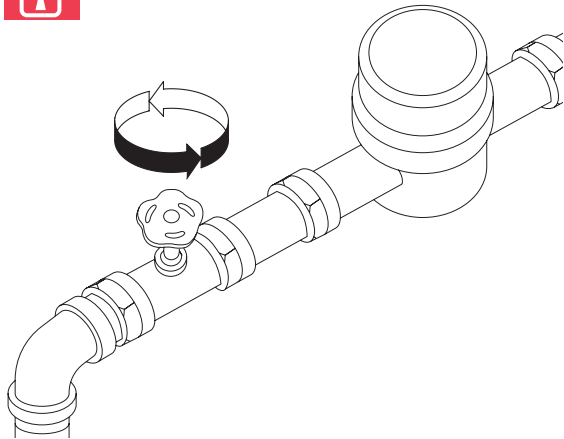
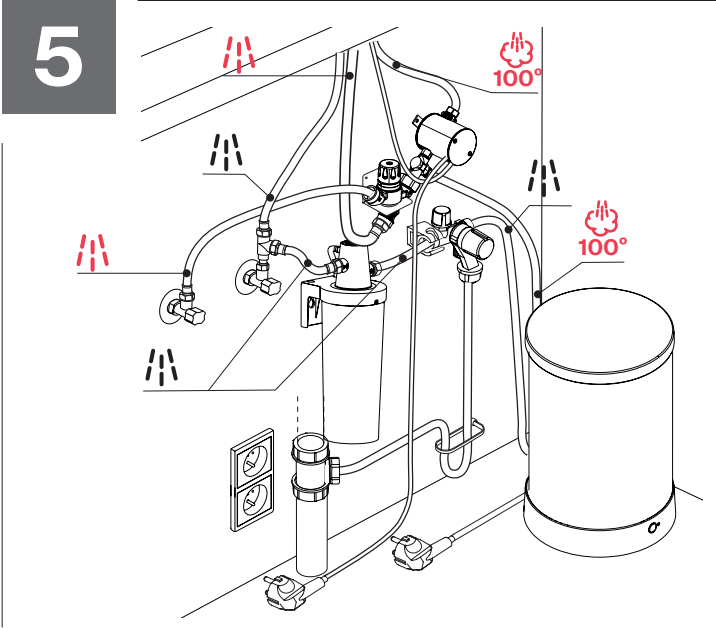
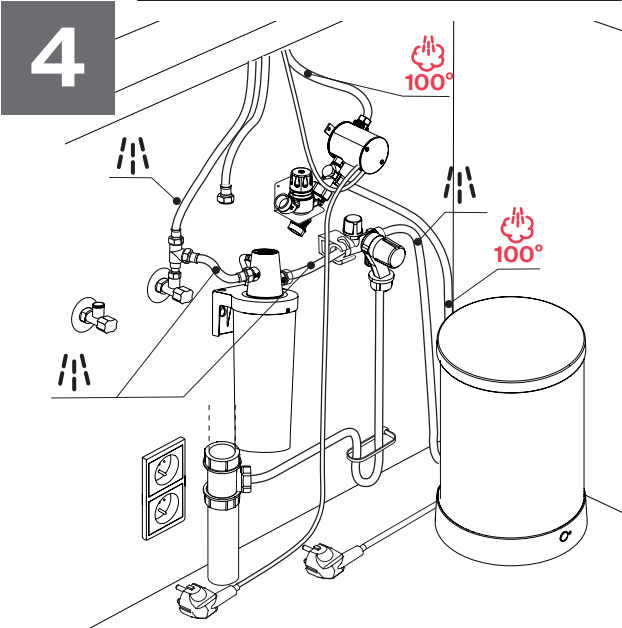

6

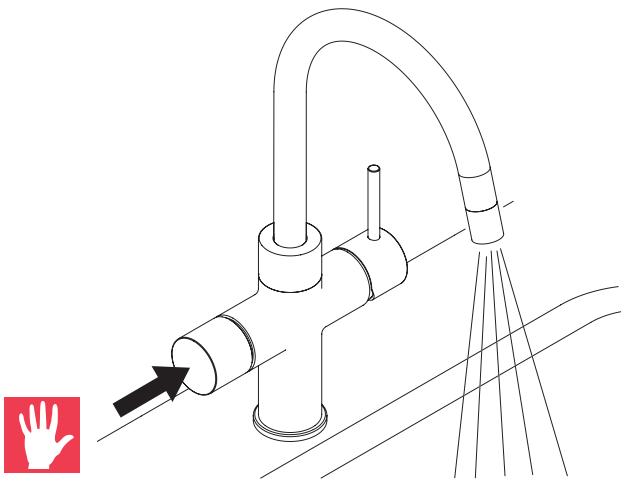
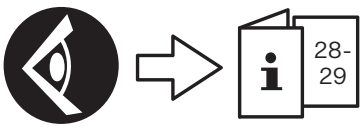
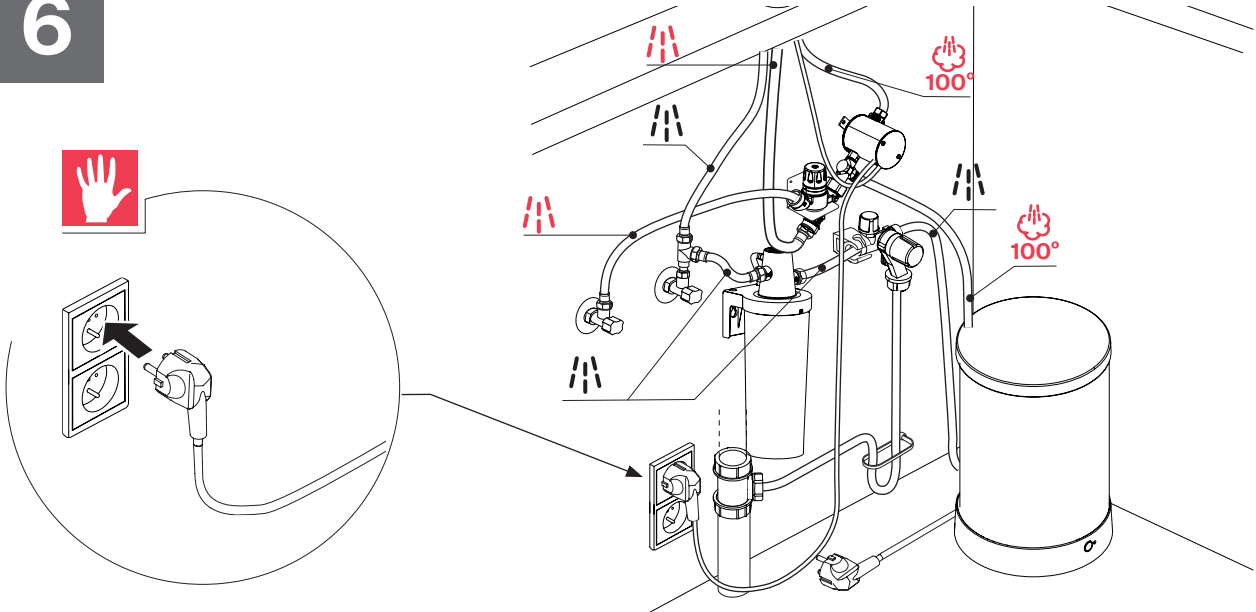

7

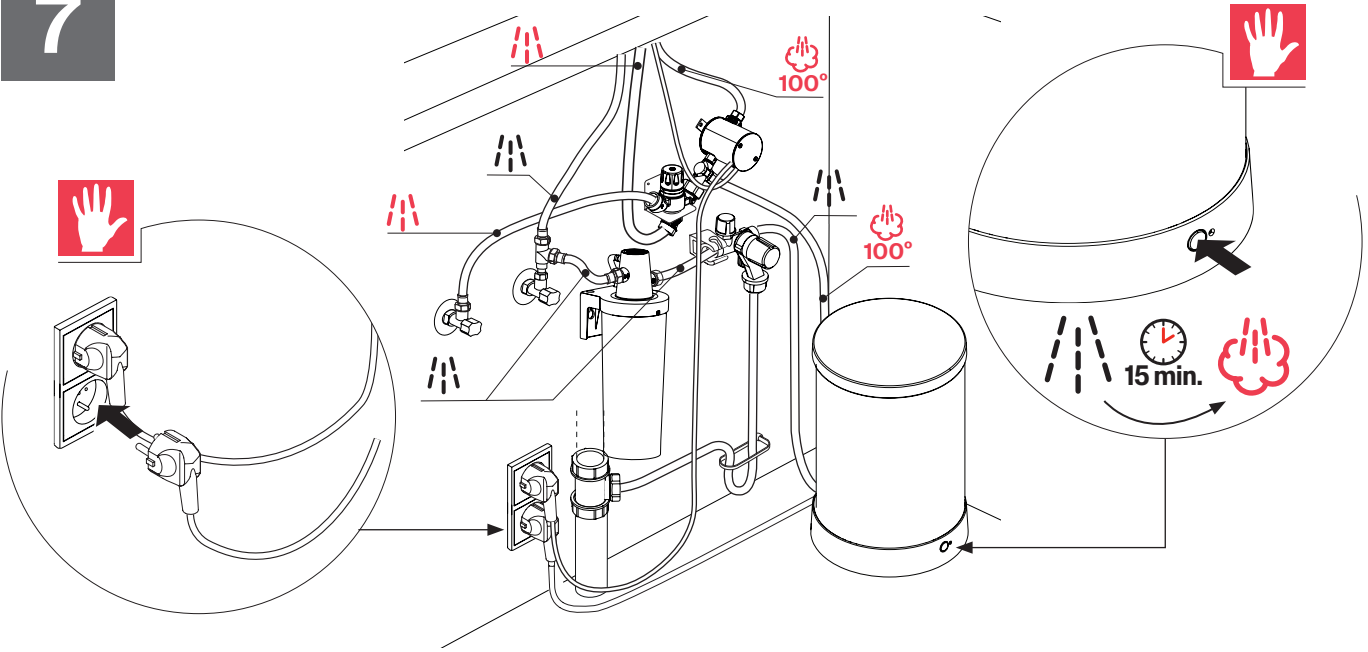

Operation

Operation of boiler

- ▶ Briefly pressing the ON/STANDBY button switches between the boiler modes ON and STANDBY.

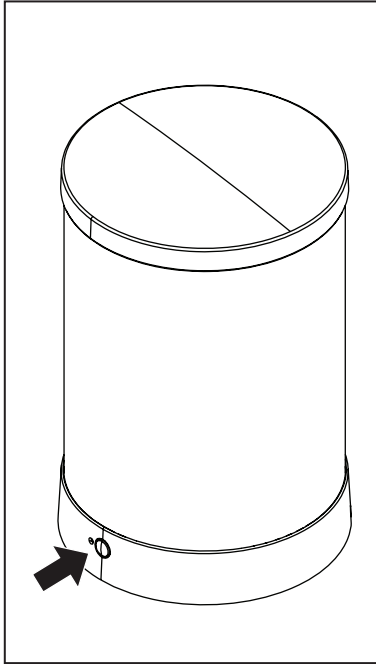

ON:

- The boiler water is heated continuously until the 103 degrees is reached.

OFF:

- The boiler is switched off and does not heat.

When the boiler has been switched off for a week, we recommend that the following procedure is observed before use:

- ▶ Switch on boiler. Wait until the boiler water is up to temperature.
- ▶ Open the boiling water tap and flush the boiling water line until cold water comes out of the tap.



Caution: Ensure that the water does not atomise during flushing.

- ▶ Heat the boiler water again.

Decommissioning boiler

1. Remove the plug of the boiler from the wall plug socket.
2. Turn on the boiling water tap.
3. Wait until cold water runs out.
4. Turn off the boiling water tap.
5. Close the stop valve.
6. Turn on the boiling water tap.
7. Wait until water no longer runs out.
8. Turn off the boiling water tap.
9. Disconnect the hoses from the boiler.
10. Remove the boiler.
11. Allow the water from the hoses and the boiler to drain into the sink.

Taking boiler out of service

If you do not expect to need any boiling water for a prolonged period, such as during holidays, you can switch off the boiler (temporarily):

- ▶ Use the boiler STANDBY mode, or remove the plug from the wall plug socket to prevent heating of the boiler.

Switching on for the first time

 Ensure that the boiler is filled with water!

Boiler

1. Operate the mixer tap and flush with warm water for 1 minute (fig. 1).
2. Open the boiling knob of the tap. The boiler will fill with water (fig. 2). Air will come out of the tap. Flush the system properly: when there is a smooth laminar flow out of the tap, the system is properly flushed.
3. Switch on the boiler (fig. 3).

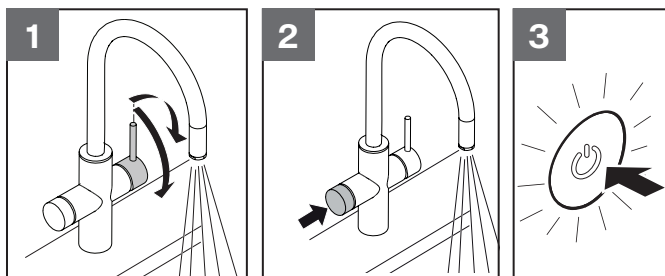

4. Inspect the installation for leaks after commissioning.

Water reaches boiling temperature after approximately 15 minutes.

 **Warning:** If, during heating, no expansion water has escaped after 10 minutes: Switch off the power supply immediately and turn on the boiling water tap to relieve the water pressure.

- ▶ The boiler is heated up when the ON/STANDBY button has a steady red light.
5. To clean the tank open the open the boiling water tap until cold water runs out.

Tap operation

Operation of mixer lever

- ▶ Select hot water (fig. 4).

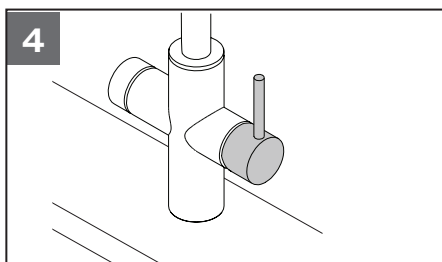

- ▶ Select cold water (fig. 5).

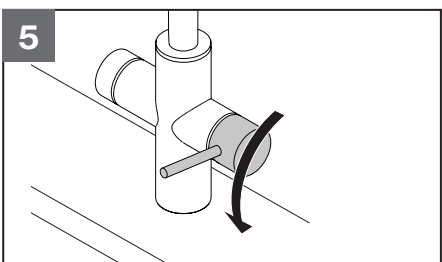

- ▶ Turn on mixer tap (fig. 6).

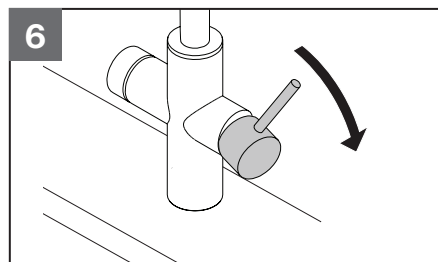

Operation of electronic knob

- ▶ Activate tap: Press briefly 1x (fig. 7).

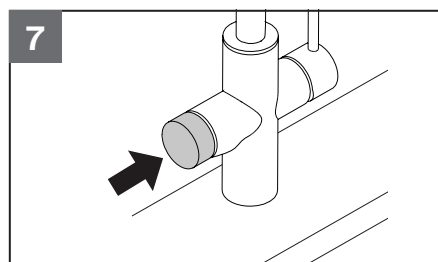

- ▶ Press and turn backwards (to activate the boiling water selection (fig. 8).

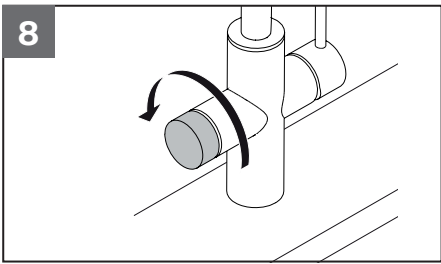

- ▶ Continues boiling water: Hold selector knob pressed (fig. 9). Deactivate: Release the knob.

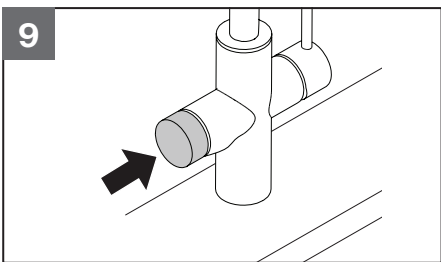

- ▶ Filling mode short: Press briefly 2x (fig. 10). Stops automatically. Deactivate: Press briefly 1x.

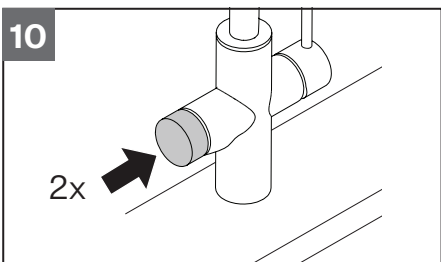

- ▶ Filling mode long: Press briefly 3x (fig. 11). Stops automatically. Deactivate: Press briefly 1x.

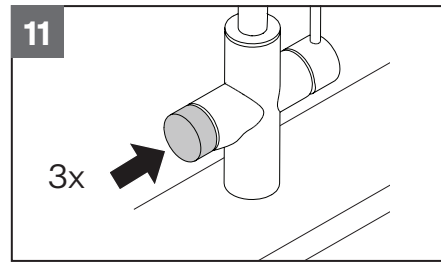

- ▶ Hold the object to be filled close to the tap so that the object surrounds the delivery opening of the tap. This will prevent (hot) water from splashing.
- ▶ For the optimum result when making coffee or tea, allow around 1 cup of water to run out before filling the pot. In this way the air bubbles in the water disappear so that no foam forms on the surface of the tea.

Filling mode

- ▶ Press 2x briefly for Pan filling. Pan filling: Boiling water (red) = 30 sec. flow.
- ▶ Press 3x briefly for Pan filling. Pan filling: Boiling water (red) = 60 sec. flow

Electronic knob status indicator LED

LED colour	LED action	Function
Red	Continous	Boiling water

Filter installation/Filter replacement

1. Press and hold the button (in the neutral positioning) for 10 seconds.
2. Turn the electronic knob backwards to select the correct color press and hold the knob for 2 seconds. The LED flash 3 times for confirmation and go back in to the neutral position.

The LED in the neutral position reminds you 1 month in advance that the filter needs to be replaced. The LED in the neutral mode switch from white to orange.

If the filter reached the expire date the orange LED starts to pulsate until the filter has been replaced.

After the filter replacement, repeat step 1 and 2. If you registered your system you will get a reminder via email.

 The use of a Franke filter is mandatory to protect the product against lime scale deposits. It is mandatory to change the filter based on the water hardness table.

Water hardness	LED colour
<10°dh	light blue
10-15°dh	yellow
15-20°dh	light green
>20°dh	purple

Selection of neutral led intensity

After 60 seconds of not using the tap it will switch automatically into the sleeping mode status, 50% led intensity.

To change the sleeping mode setting you have to follow the below instruction.

1. Activate the tap by pressing the electronic knob once.
2. Press the electronic knob 5 times.
3. The LED start flashing.
4. Turn the knob to the preferred setting by turning the knob front or backwards:
 - 1: 50% intensity, default
 - 2: 10% intensity
 - 3: Switched off fully
5. After the selection press the electronic knob for 2 seconds to confirm. The tap flashes 3 times for confirmation.

Messages and malfunctions

Boiler messages

LED colour	LED action	Description
Blue	Blinking	Boiler does not have water.
Blue	Steady	Commissioning/system self-check.
Orange	Blinking	System failure; contact Franke service.
Red	Blinking	Boiler is heating up.
Red	Steady	Boiler is fully heated.

Tap messages

LED colour	LED action	Function	Description
Red	Steady	Boiling Water	Selection of Boiling Water is possible.
Red	Rotating	Selection of boiling water is ongoing.	Selection of boiling water is ongoing.
Orange	Steady	Filter	Filter cartridge is almost finished and must be replaced within one month.
Orange	Pulsating	Filter	Filter is overdue and needs to be replaced direct.

Troubleshooting

Electronic knob does not respond

Cause	Remedy
Software problem.	Disconnect the power supply for at least 10 seconds.
The cable connector of the tap is not correctly connected.	Plug the cable connector securely.
The wall plug socket has no power supply.	Check the electricity supply. The electricity group has failed due to an excessive load. The boiler cannot be connected to the same electricity group as a dishwasher. Franke suggest the Power combiswitch 112.0561.116.
The cable or connector of the tap is damaged or defective.	Contact Franke.

Water leaks

Cause	Remedy
Connection leaking	Inspect the coupling(s) and re tighten, if necessary.
Hose(s) leaking	Inspect the hose(s) and replace the leaking hose(s).
Boiler leaking	Remove the plug of the boiler from the wall plug socket. Shut off the water supply. Contact Franke.
Tap leaking	Shut off the water supply. Contact Franke.

Tap supplies no water

Cause	Remedy
Hose(s) kinked.	Inspect the hose(s) and straighten the kinked hose(s).
The main water valve is closed.	Open the main water valve.
The stop valve in the kitchen cabinet is closed.	Open the stop valve.

Tap supplies no boiling water

Cause	Remedy
Hose(s) kinked.	Inspect the hose(s) and straighten the kinked hose(s).
PRV is closed.	Open by turning the knob.
Filter not or not correctly installed.	Ensure filter is locked in.
Electronic knob not connected with socket.	Ensure electrical connections are connected.

Tap supplies no warm water

Cause	Remedy
Hose(s) kinked.	Inspect the hose(s) and straighten the kinked hose(s).
Boiler not functioning.	See table "The water from the tap is not boiling".
Warm water appliance not functioning.	Consult the manual of your warm water appliance, warm water support or Bypass.

The water from the tap is not boiling

Cause	Remedy
The plug of the boiler has not been inserted into a wall plug socket.	Insert the plug into an earthed wall plug socket.
The wall plug socket has no power supply.	Check the electricity supply. The electricity circuit has failed due to an excessive load. The boiler cannot be connected to the same electricity circuit as a dishwasher. Franke suggest the Power combiswitch 112.0561.116.
The boiler is OFF (wait mode).	Switch the boiler ON.
The boiler has not heated up completely.	Wait until the boiler has heated up.
The boiler is defective.	Contact Franke.

The boiler causes a short-circuit

Cause	Remedy
There is a short-circuit in the electric wiring or the heater element of the boiler.	Remove the plug of the boiler from the wall plug socket. Contact Franke.
No water in the boiler.	Fill the boiler with water.

Maintenance

General maintenance

- ▶ Clean the tap only with Franke tap cleaner.
- ▶ Do not use cleaning agents containing a solvent or acid, such as lime scale removers, household vinegar or cleaning agents with acetic acid. These substances damage the surface. The tap will become matt and scratched.
- ▶ Lime scale deposits can be prevented by drying the tap after use.
- ▶ If lime scale deposits nevertheless occur, remove these using a citric acid-based cleaning agent.
- ▶ Always use original Franke parts for maintenance or repair. This guarantees the safety and proper function of the product and safeguards any warranty claims.
- ▶ Replacement or repair of parts may only be carried out by Franke Service.

Replace filter

- ▶ Turn filter clock wise to remove from filter head.
- ▶ Turn new filter anti clock wise to install. Reset the filter setting see page 29 (filter installation).
- ▶ The filter head has an integrated auto shut off water valve. No need to isolate water supply to change filter.

Descaling tap aerator

- ▶ **Always use a citric acid-based descaling agent.** Other substances will damage the material!
- ▶ Loosening and tightening can be made easier by wrapping an elastic band around the sleeve of the tap aerator. Take care that the sleeve of the tap aerator is not damaged by the use of tools.
- ▶ Over the course of time, lime scale deposits will appear on and alongside the tap aerator.
- ▶ Unscrew the sleeve of the tap aerator (fig. 12).
- ▶ Clean the tap aerator using a suitable descaling agent (fig. 13).
- ▶ Place the tap aerator into the sleeve (fig. 14).
- ▶ Place the gasket onto the tap aerator (fig. 15) and screw on the sleeve finger-tight (fig. 16).

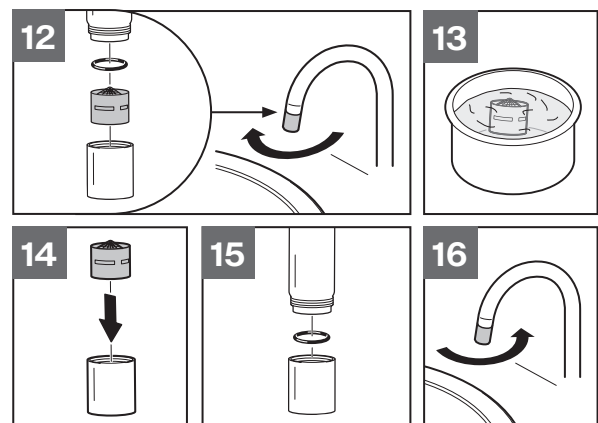

Disposal



The symbol on the product or on the packaging indicates that the device must not be disposed of in the domestic waste. By disposing of the device in a proper way you help to avoid harmful consequences to environment and health.

Further information about recycling the device is available from the competent authority, the local refuse disposal service or the vendor of the device.

Dispose of the device, which is to be discarded, via a specialised waste collection point for electronic and electrical devices.

In accordance with the article of Legislative Decree no. 15 dated 25 July, Implementation of Directive 2002/96/EC regarding the reduction of the hazardous substances used in electrical and electronic appliances and in waste disposal.

The barred dustbin symbol on the appliance indicates that at the end of its working life the product must not be disposed of as household waste.

Consequently, when the appliance has reached the end of its working life the user must take it to a suitable recycling centre for electronic and electrotechnical waste, or return it to the dealer when purchasing a new appliance of equivalent type.

Proper separate waste collection of the scrapped appliance for subsequent recycling, treatment and environmentally-friendly disposal helps prevent a potentially negative impact on the environment and health and facilitates recycling of the materials used in appliance construction.

Inhoudsopgave

Over deze handleiding	37
Veiligheidsinformatie	37
Algemeen	37
Kraan	38
Filterpatroon	38
Garantie	39
Installatievoorschriften	39
Productinformatie	40
Systeem	40
3-in-1 elektronische kraan	40
Hydraulische box	40
Filter	41
Boiler	42
Legenda pictogrammen	43
Installatie	44
Algemene uitgangspunten voor installatie	44
Installatiestappen	44
Bediening	59
Bediening van de boiler	59
De boiler buiten bedrijf stellen	59
De boiler buiten gebruik stellen	59
Voor het eerst inschakelen	60
Kraanbediening	60
Bediening van de menghendel	60
Bediening van de elektronische knop	60
Vulmodus	61
Led-indicatie status elektronische knop	61
Filter installeren / vervangen	61

Selectie van lichtsterkte elektronische knop	62
Meldingen en storingen	62
Boilermeldingen	62
Meldingen kraan	63
Probleemoplossing	63
Onderhoud	65
Algemeen onderhoud	65
Filter vervangen	65
Ontkalken van het zeefje	65
Afvalverwijdering	66

Over deze handleiding

Deze handleiding bevat belangrijke informatie over de veilige en correcte installatie en inbedrijfstelling van het product.

FRANKE behoudt zich het recht voor om zonder voorafgaande kennisgeving wijzigingen aan het product aan te brengen. Alle informatie is correct op het moment van uitgifte.

- ▶ Lees de handleiding zorgvuldig door voordat u het toestel in gebruik neemt.

- ▶ Bewaar de handleiding.
- ▶ Gebruik het in deze handleiding beschreven toestel alleen in overeenstemming met het beoogde gebruik.

Symbol	Betekenis
	Waarschuwingssymbool. Waarschuwing voor risico's op letsel.
	Handeling. Geeft een handeling aan die moet worden uitgevoerd.



Waarschuwingssymbool. Waarschuwing voor risico's op letsel.



Handeling. Geeft een handeling aan die moet worden uitgevoerd.

Veiligheidsinformatie

Algemeen

 Installeer het product zoals beschreven in deze handleiding en in overeenstemming met de van toepassing zijnde installatie-, veiligheids- en lokale watervoorzieningsvoorschriften!

 Gebruik het product niet voor andere doeleinden dan die waarvoor het bestemd is, zoals in deze handleiding is beschreven.

 Er mogen geen wijzigingen aan het product worden aangebracht.

 Steek de stekker alleen in een geaard stopcontact.

 Als deze kraan wordt gebruikt door kinderen onder de 12 jaar en door personen met verminderde lichamelijke, zintuiglijke of mentale capaciteiten, of die niet over de nodige ervaring of kennis beschikken, is dit alleen toegestaan onder toezicht of na duidelijke instructies over het veilige gebruik van het product en als zij zich bewust zijn van de gevaren die kunnen voortvloeien uit het gebruik van het product en/of het systeem.

 Reiniging en onderhoud door de gebruiker mogen niet zonder toezicht worden uitgevoerd door kinderen of door personen met verminderde lichamelijke, zintuiglijke of mentale capaciteiten, of die niet over de nodige ervaring of kennis beschikken.

 Voorkom dat kinderen met het product en/of het systeem spelen.

 Dit product en/of systeem is bedoeld voor gebruik in huishoudelijke en soortgelijke omgevingen, waaronder:

- personeelskeukens in winkels, kantoren en andere werkomgevingen;
- door gasten in hotels, motels en andere soortgelijke residentiële omgevingen;
- B&B-accommodaties en andere soortgelijke woonomgevingen.

 Gebruik in andere omgevingen is alleen toegestaan in overleg met de fabrikant van het product en/of systeem.

 Als de voedingskabel met stekker beschadigd is, moet deze worden vervangen door de fabrikant, de klantenservice van de fabrikant of een

gekwalificeerd persoon om elektrische schokken te voorkomen.

 Indien nodig de O-ringen alleen met siliconenvet smeren.

 Om bevriezing te voorkomen, mag het product alleen in vorstvrije ruimtes worden geïnstalleerd.

 Veiligheidsvoorschriften moeten in acht worden genomen om lichamelijk letsel en/of schade aan het product en/of het systeem te voorkomen.

 Onderhoudsvoorschriften moeten in acht worden genomen om schade en overmatige slijtage te voorkomen.

 Als gevolg van de voortdurende verbetering van onze producten en/of systemen kunnen de afbeeldingen in dit document afwijken van het geleverde toestel.

 Indien voorhanden, kunt u de laatste versie van de handleiding downloaden via onze website: www.franke.com

 Franke kan niet aansprakelijk worden gesteld voor kosten, schade of persoonlijk letsel als het product niet in overeenstemming met de voorschriften in deze handleiding wordt gebruikt.

 Het model van de kraan en van de boiler kan afwijken van het model dat in de handleiding is afgebeeld.

Kraan

 Voorkom brandwonden en verbranding en let op bij het gebruik van warm water. De temperatuur van het warme water kan hoger zijn dan 55 °C.

 Voorkom brandwonden en verbranding en let op bij gebruik van kokend water. De temperatuur van het water kan hoger zijn dan 100 °C.

 Betegelde en stenen gootstenen zijn niet bestand tegen kokend water; door het

temperatuurverschil kunnen er barsten in ontstaan. Open altijd de koudwaterkraan als u kokend water weggiet en giet het kokende water bij voorkeur rechtstreeks in de afvoer.

Boiler

 Controleer vóór de inbedrijfstelling of de boiler met water is gevuld.

 Gebruik nooit de slangen of het netsnoer om de boiler op te pakken of te dragen.

 Het toestel moet altijd op de koudwatertoevoer worden aangesloten.

 Alvorens de boiler te installeren moet worden gecontroleerd of de uitlaat van de overdrukklep zich 8 cm boven de aansluiting van de afvoerleiding bevindt.

 De afvoerslang moet met een continu neerwaarts verloop worden aangesloten en er moet een sifon worden gemaakt; het kan dus nodig zijn de afvoerslang door te knippen.

Filterpatroon

 Het is verplicht om een Franke filter te gebruiken teneinde het product tegen kalkaanslag te beschermen. Het is verplicht om het filter te vervangen op basis van de waterhardheidstabel

 Als het filter bij een temperatuur van 0 °C is opgeslagen, moet het vóór installatie eerst 24 uur bij kamertemperatuur worden bewaard.

 Het filterpatroon mag niet worden geopend of beschadigd.

 Het filterpatroon en het systeem moeten na een langdurige stilstand en/of tijdens onderhoudswerkzaamheden intensief worden doorgespoeld (2 liter spoelwater na 1 week stilstand; 10 liter spoelwater na 4 weken stilstand).

 Het filterpatroon moet worden vervangen als het na de inbedrijfstelling 3 maanden lang niet in gebruik is geweest.

Garantie

Scan de QR-code om bij de garantiebepalingen te komen:



Installatievoorschriften

 **Let op:** Gebruik om beschadigingen te voorkomen nooit gekarteld gereedschap. Gebruik waar nodig altijd het juiste gereedschap voor het aandraaien van het koppelstuk.

► Minimale buigradius na installatie.

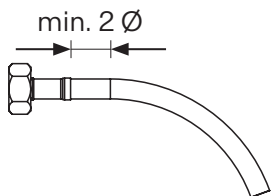
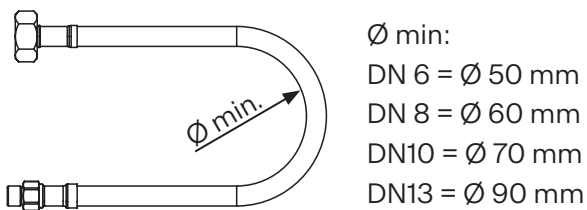

► Zonder knikken na installatie.

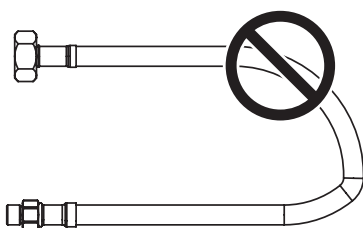

► Zonder knik direct na aansluiting.



► Zonder trekspanning na installatie.

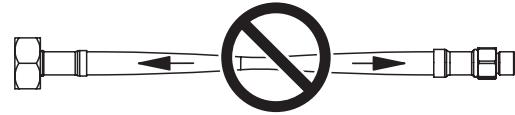

► Zonder torsie na installatie.

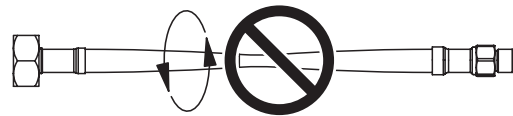

Productinformatie

Stelsysteem

Watertoevoerdruk (min.)	100 kPa/14,5 psi/1 bar
Watertoevoerdruk (max.)	500 kPa/72,5 psi/5 bar
Debiet kokend water	2 - 4 l/min * 2,5 bar
Debiet koud water	5 - 9 l/min *
Debiet heet water	5 - 9 l/min *

* Het debiet varieert, afhankelijk van de waterdruk en het type kraan.

3-in-1 elektronische kraan

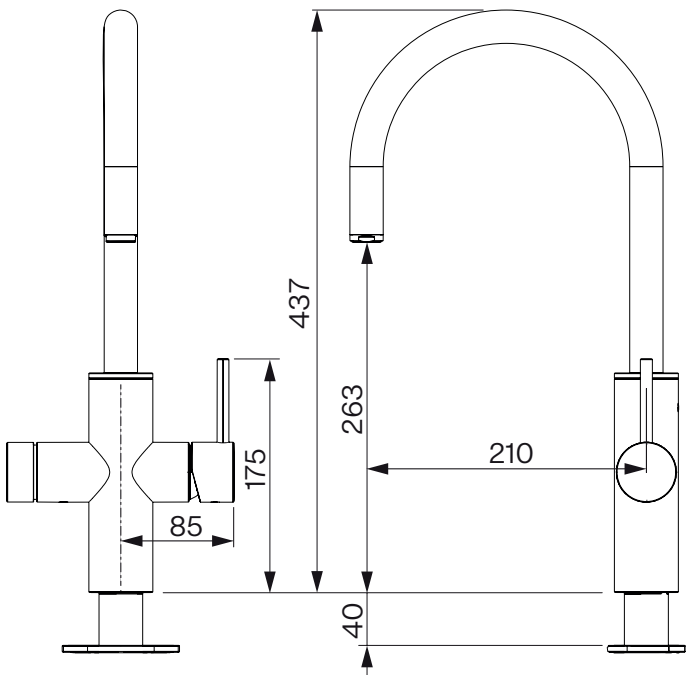

Hydraulische box

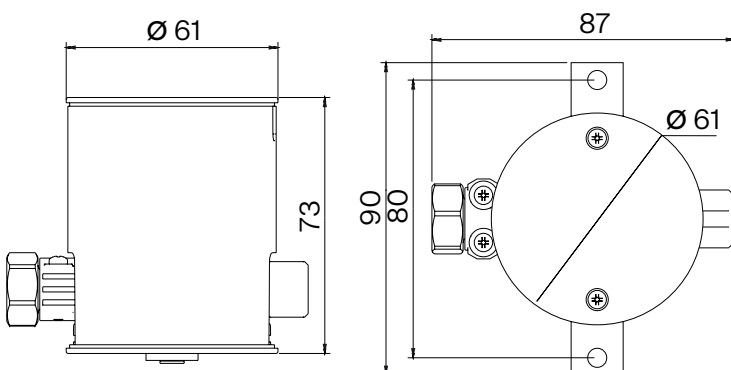

Filter

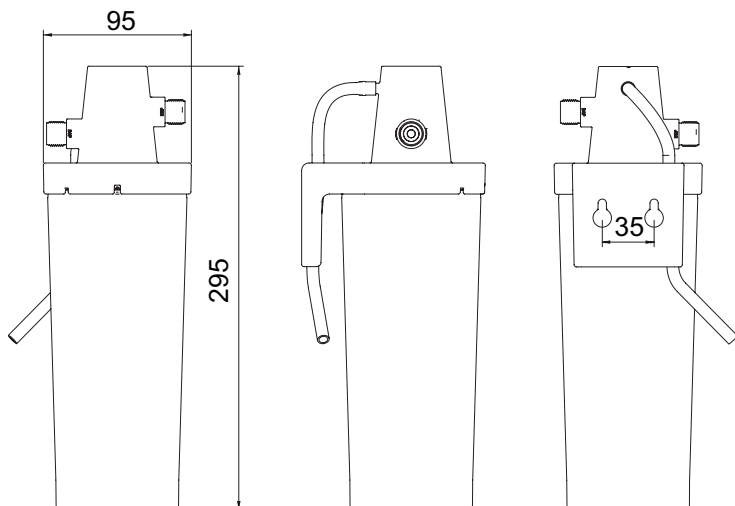

Filtertype	Beschermingsfilter
Diameter	95 mm
Hoogte incl. filterkop	295 mm
Filterkop	Bajonet/afzonderlijk onderdeel

Levensduur filter

Waterhardheid	<10°dH = 12 maanden
	10-15°dH = 10 maanden
	15-20°dH = 8 maanden
	>20°dH = 6 maanden

Filterafvoer restafval

Decarbonisatie	Ja
Geuren	Ja
Chloor	Ja
Deeltje	Ja
Microplastics	Ja

 Het is verplicht om een Franke filter te gebruiken teneinde het product tegen kalkaanslag te beschermen. Het is verplicht om het filter te vervangen op basis van de waterhardheidstabel.

Boiler

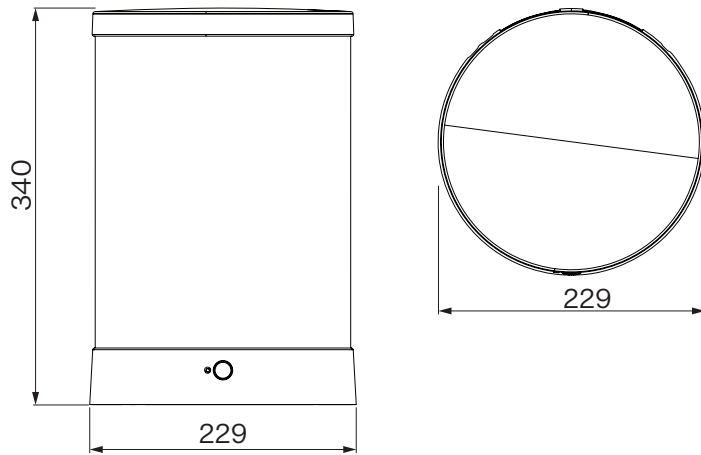

Boiler	4 liter
Afmetingen [H x B]	340 x 229 mm
Nettogewicht	4,5 kg
Inhoud	4 l
Spanning	230 VAC
Vermogen	2100 W (+5%/-10%)
Belasting	9,2 A
Standby-modus max.	14 W
IP-classificatie	IPX4
Opslagtemperatuur	<105 °C
Opwarmingstijd [ΔT 100 K]	15 min
Bedrijfsdruk (max.)	800 kPa / 116 psi / 8 bar
Bedrijfstemperatuur:	0-40 °C
EU-stroomtoevoer:	type E+F CEE 7/7 Schuko
UK-stroomtoevoer:	type G/ BS 1363 British 3 Pins
Opgegeven capaciteitsprofiel	XXS
Energie-efficiëntieklasse waterverwarming	A
Energie-efficiëntie waterverwarming	35,15 %
Jaarlijks elektriciteitsverbruik	523 kWh
Temperatuurinstelling thermostaat	103 °C















Vereisten waterkwaliteit

pH-waarde	7 - 9,5
-----------	---------



Let op: Boiler kan alleen verticaal worden geïnstalleerd (aan/uit knop moet aan de onderkant gepositioneerd zijn).

Legenda pictogrammen

	Productinformatie		Controleren
	Leveringsomvang		Positie bepalen
	Monteren		Open
	Gereedschapsuitrusting		Gesloten
	Geen gereedschap gebruiken		Weggoaien
	Meten		Koud water
	Boren		Warm water
	Schroeven		Kokend water
	Aanspannen		Niet doen / verboden resultaat
	Snijden		Doen, OK! / resultaat
	Handvast aandraaien		url / videolink
	Waarschuwbord / voorzichtig / gevaar		

Installatie

Algemene uitgangspunten voor installatie

Voer vóór het begin van de installatie de volgende stappen uit.

1. Stopkranen moeten al geïnstalleerd zijn.
2. Als de waterdruk boven de 5 bar ligt, moet er een reduceerventiel (3 bar) worden gebruikt.
3. Sluit de stopkranen.
4. Verwijder in bestaande installaties de kraan, de slangen en de boiler, als deze nog aanwezig zijn.
5. Geef de bestaande koud- en warmwateraansluiting aan.
6. Er moeten twee stopcontacten voorhanden zijn voor aansluiting.



Installeer de overdrukventiel zo hoog mogelijk in de keukenkast.

Installatiestappen

1. Installeren 3-in-1-kraan (zie pagina 46)
2. Installeren filter (zie pagina 47)
3. Installeren overdrukventiel (zie pagina 48)
4. Aansluiten afvoerslang (zie pagina 49)
5. Installeren boiler (zie pagina 49)
6. Installeren Hydraulic Box (zie pagina 49)
7. Aansluiten Hydraulic Box (zie pagina 50)
8. Aansluiten kraan 3-in-1 kraan (zie pagina 50)
9. Activeren Hydraulic Box (zie pagina 51)
10. Boiler spoelen (zie pagina 51)
11. Aansluiten en aanzetten boiler (zie pagina 51)
12. Installatie met WWS (zie pagina 52, 53, 54 en 55)
13. Installatie met Bypass (zie pagina 56, 57 en 58)
14. Inbedrijfstellen (zie pagina 59)

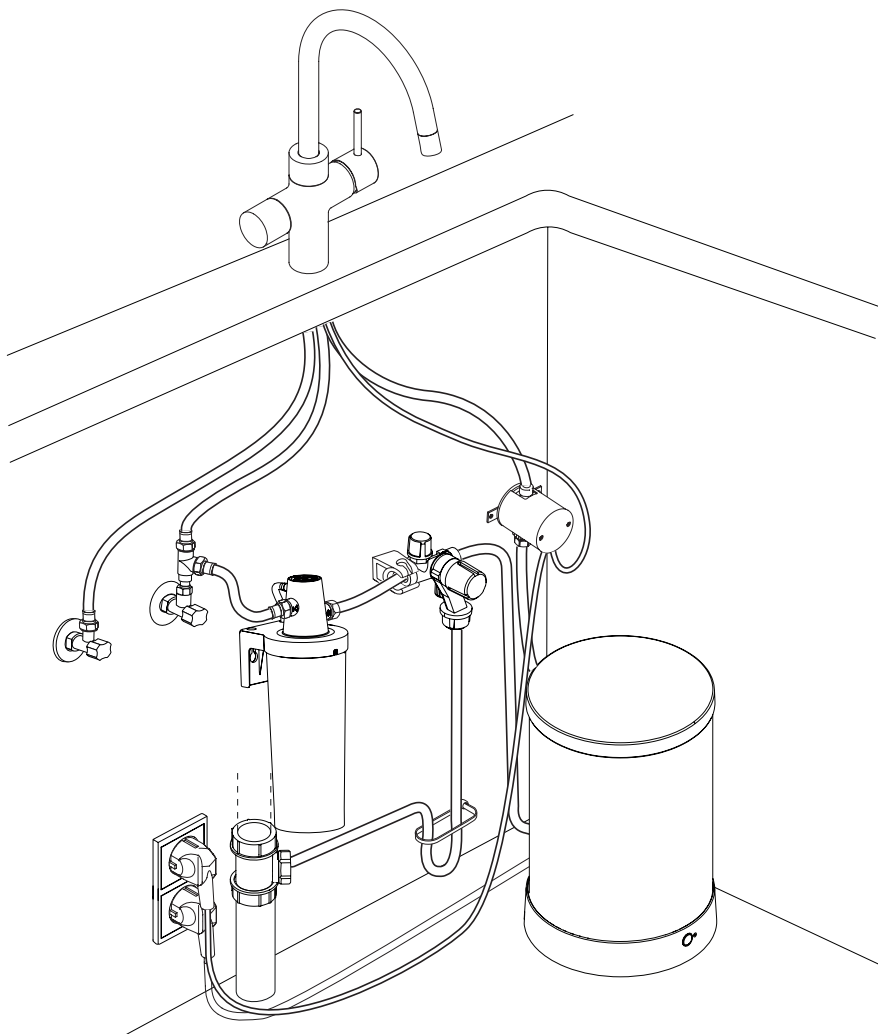
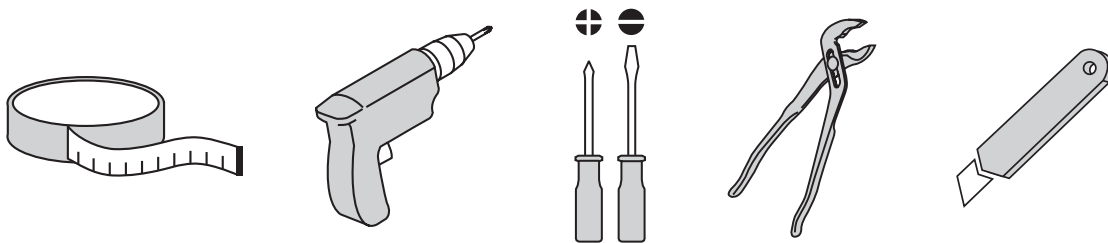
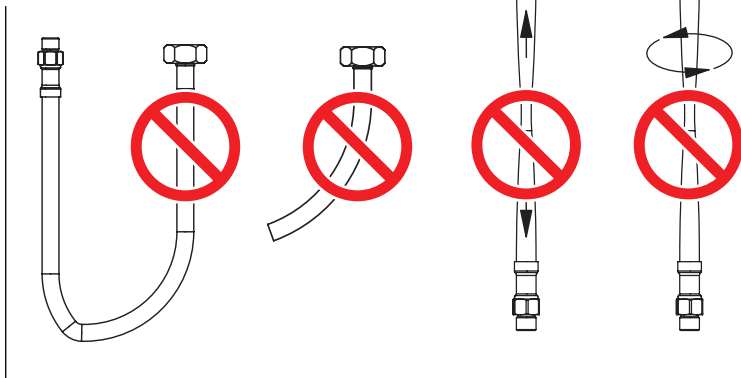

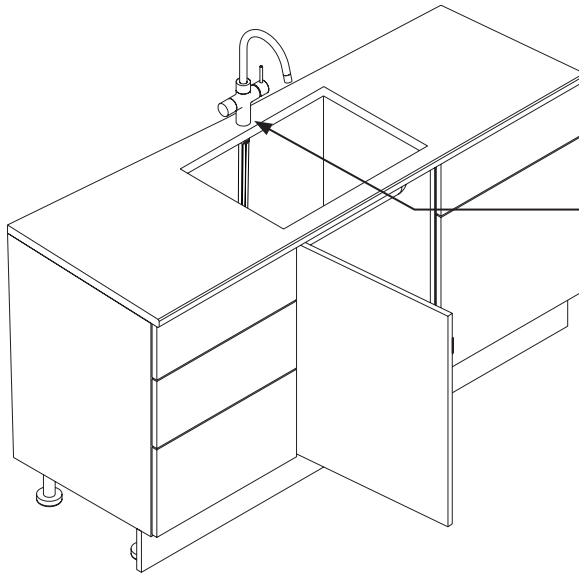

min. 40 mm
ø 35 mm
min. 30 mm

1

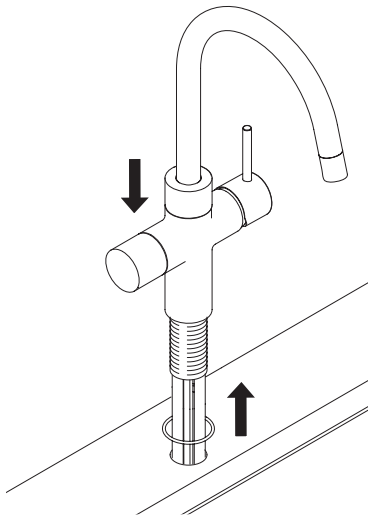

2

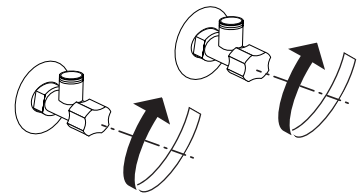
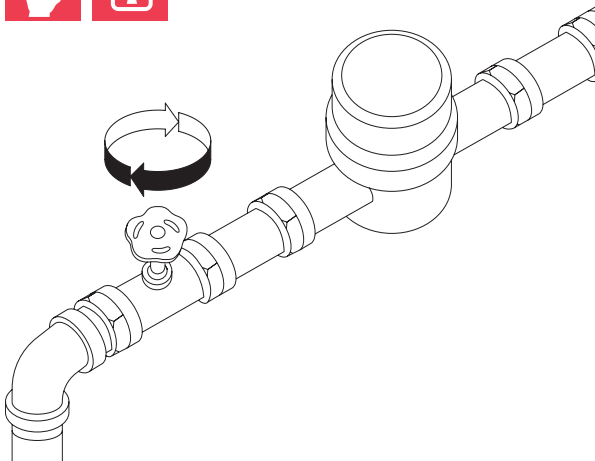
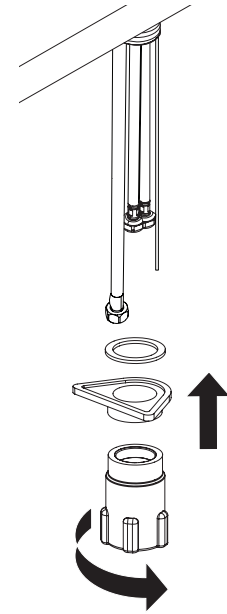

1

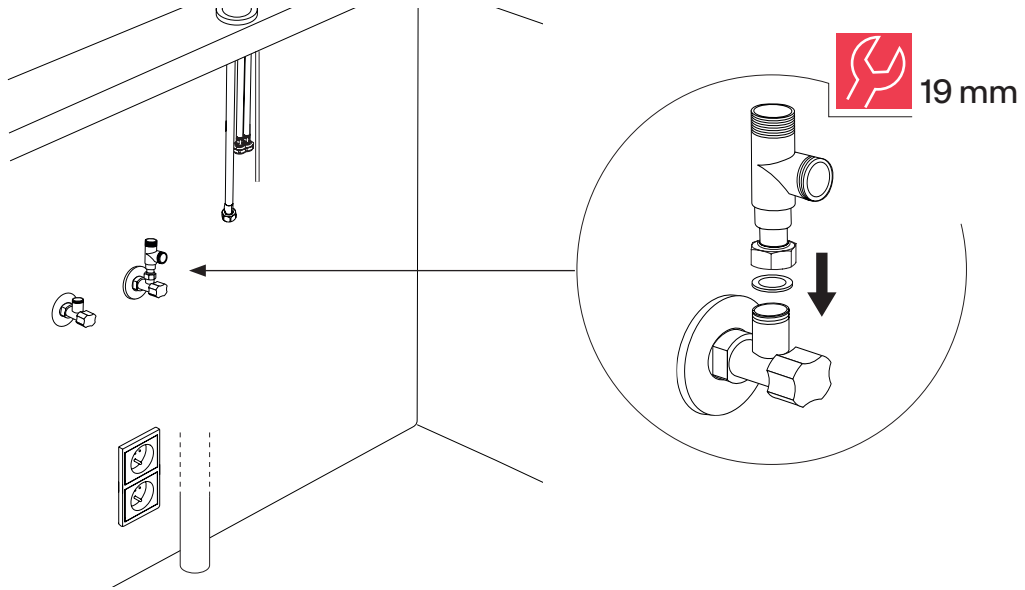

2

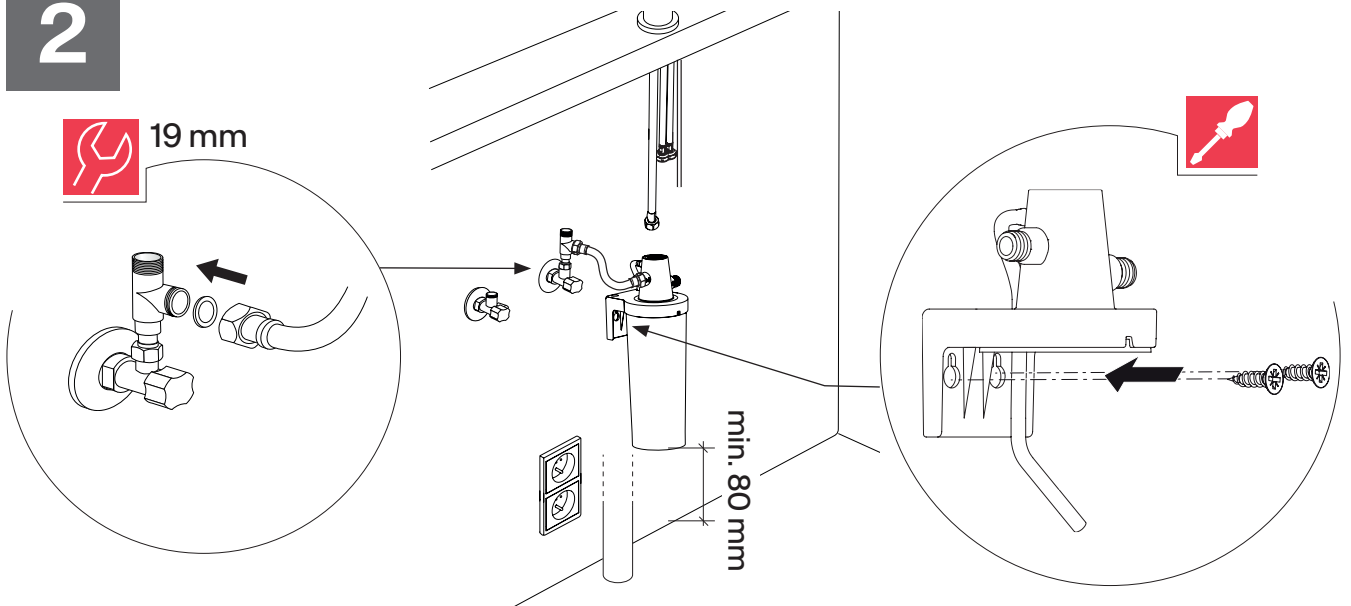

i

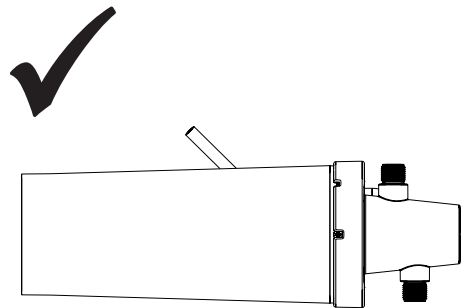
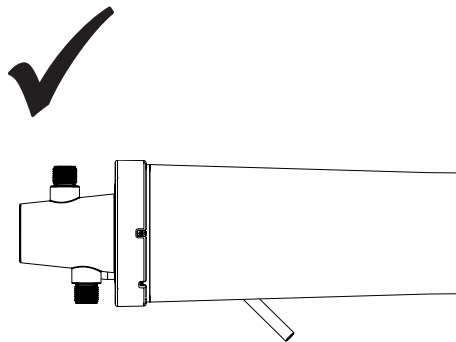
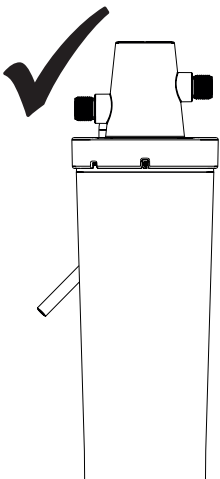

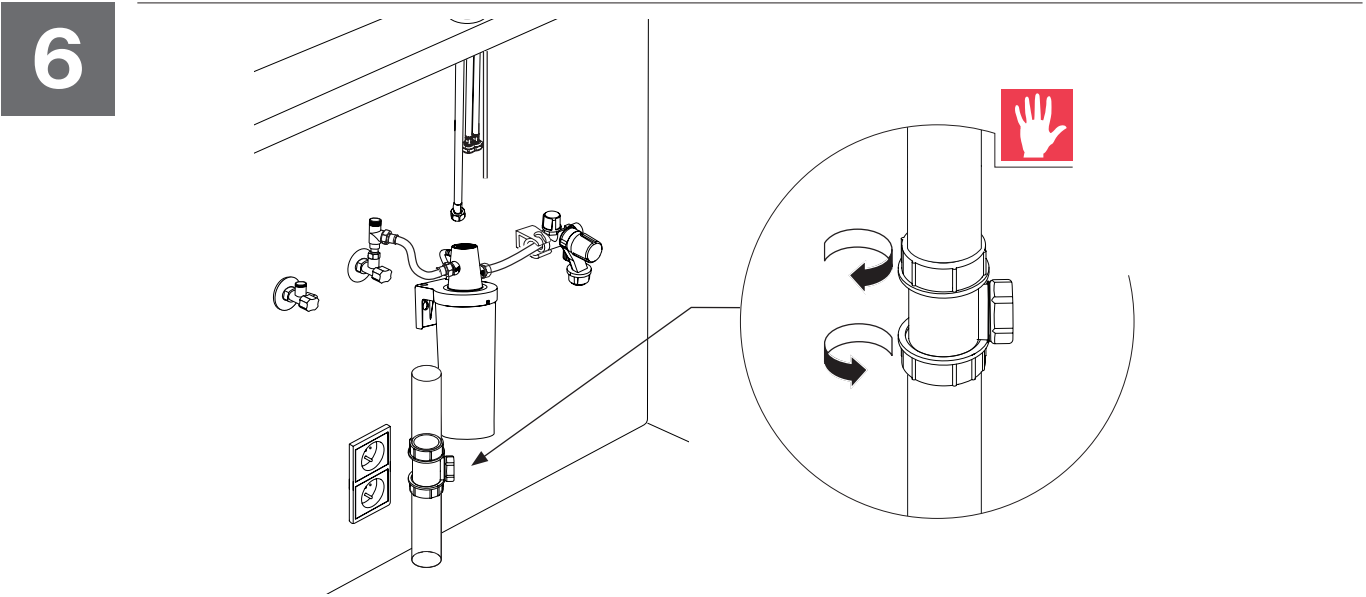
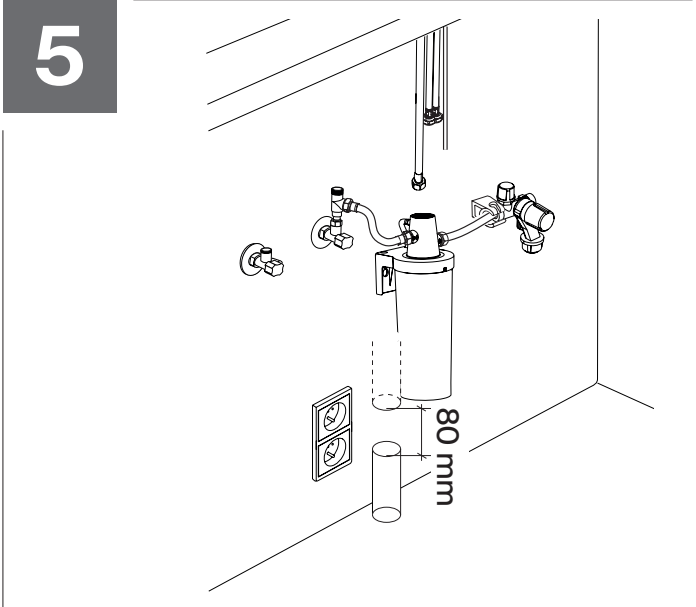
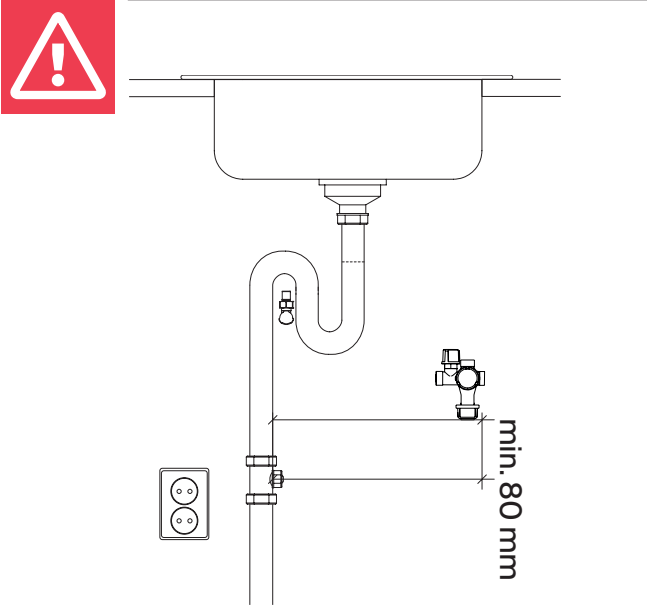
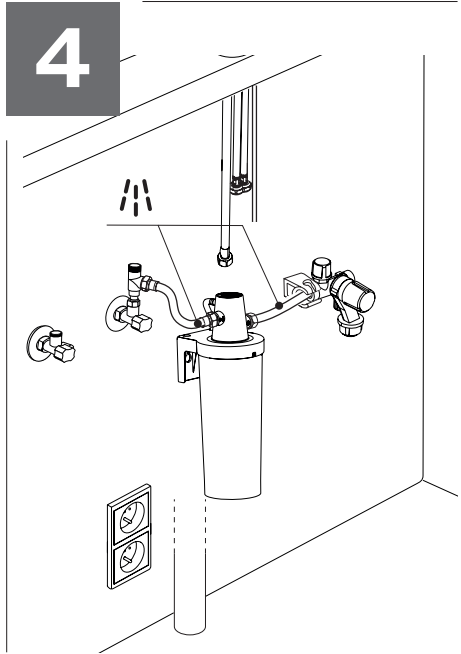
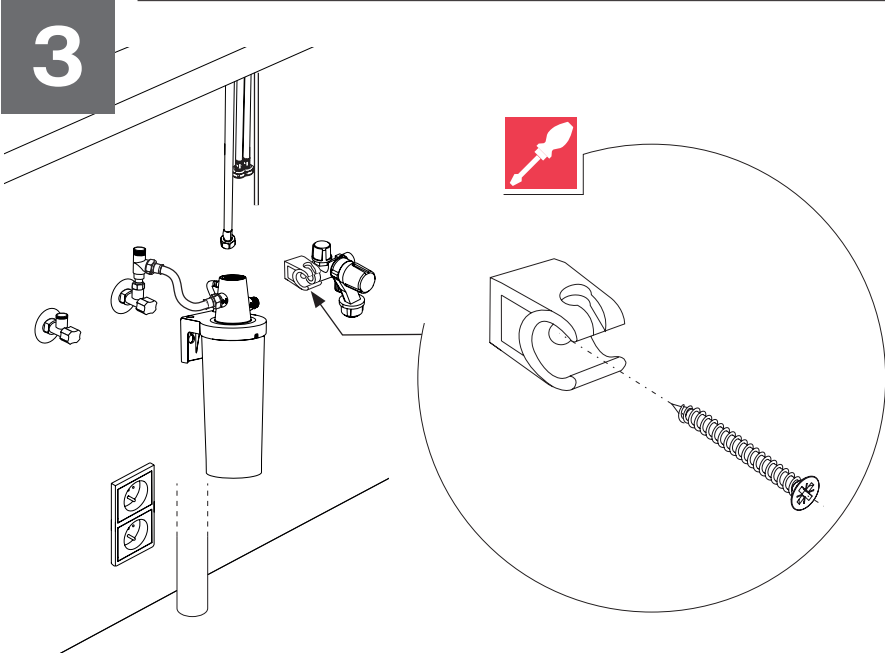

7

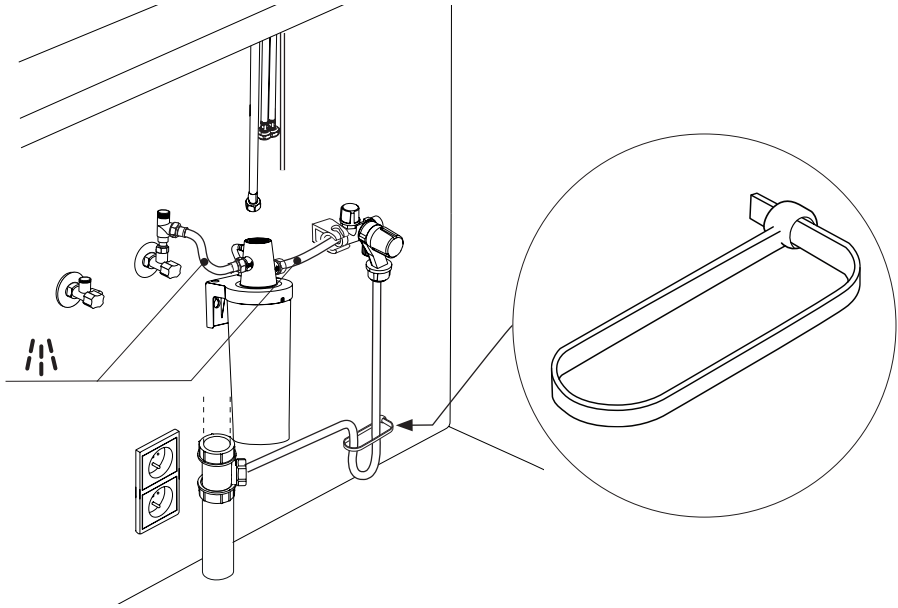

8

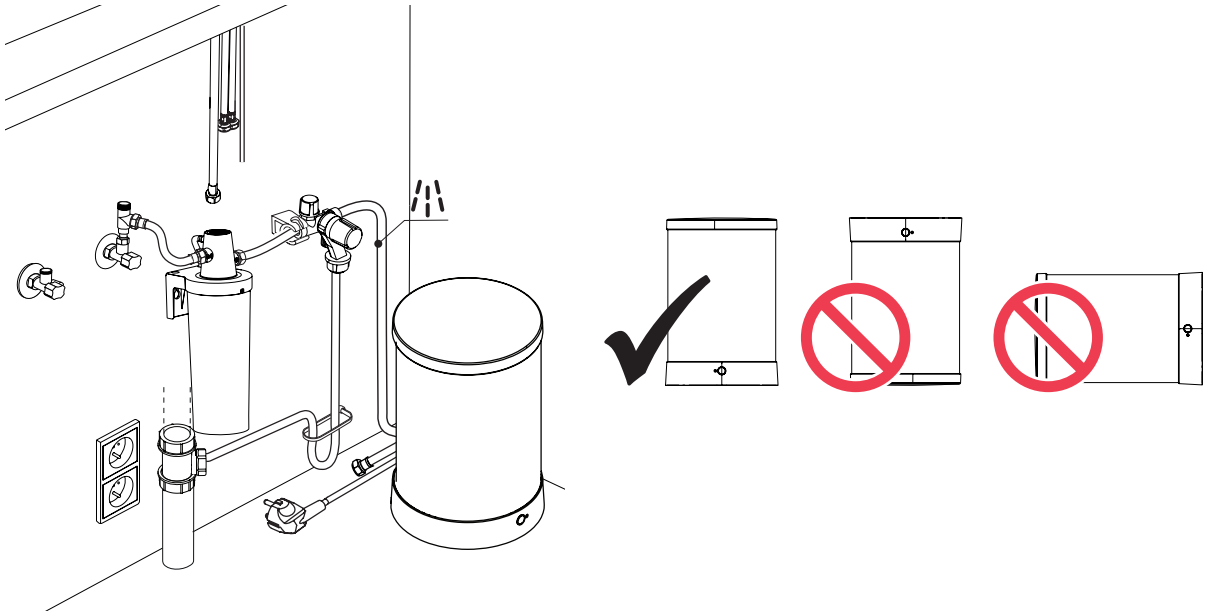

9

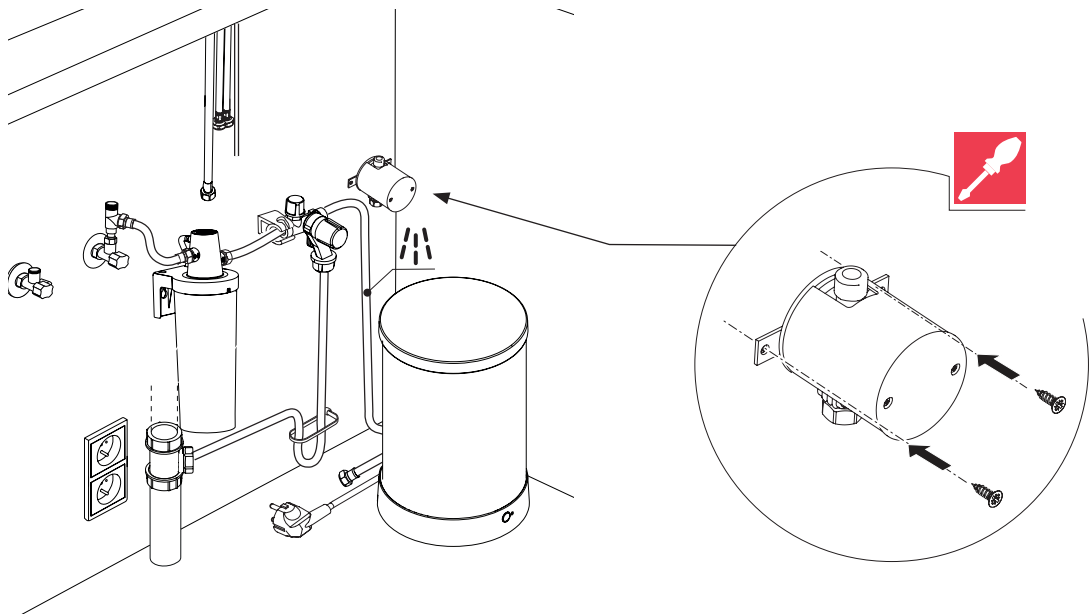

10

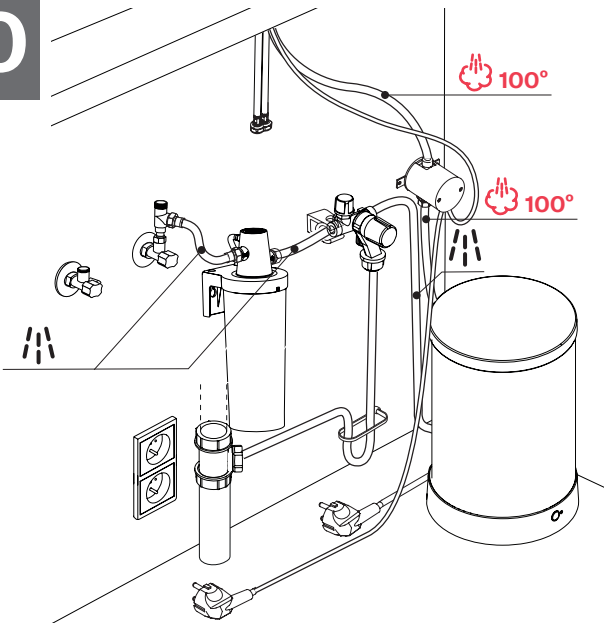

11

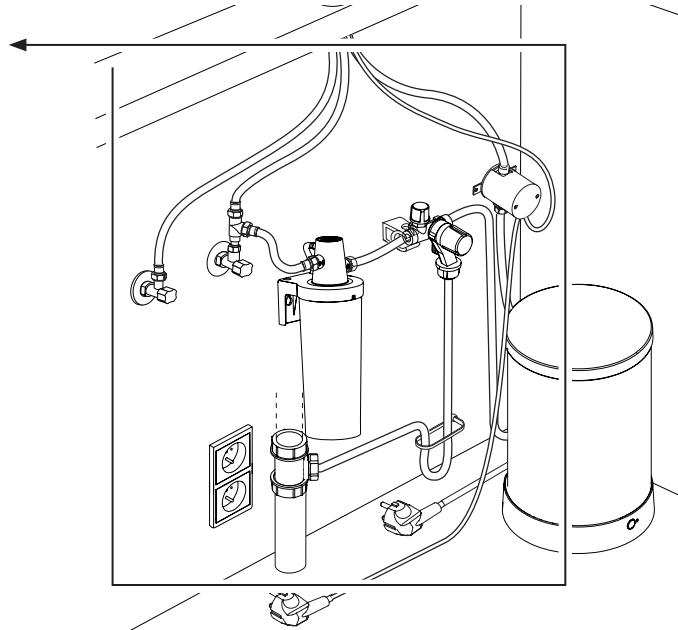
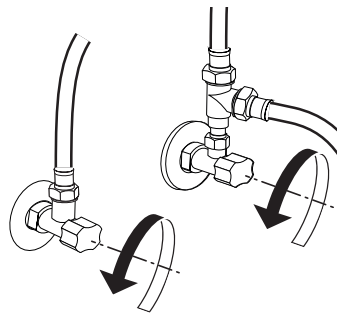
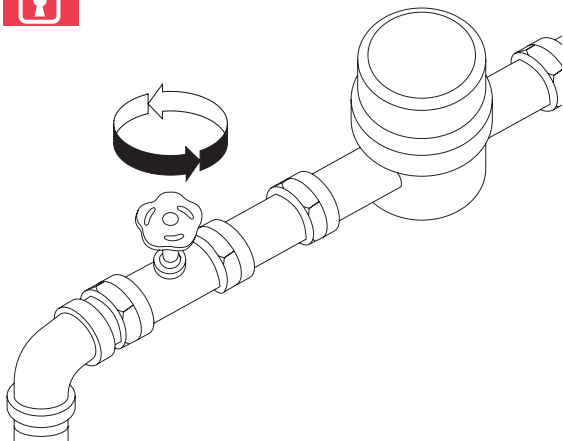
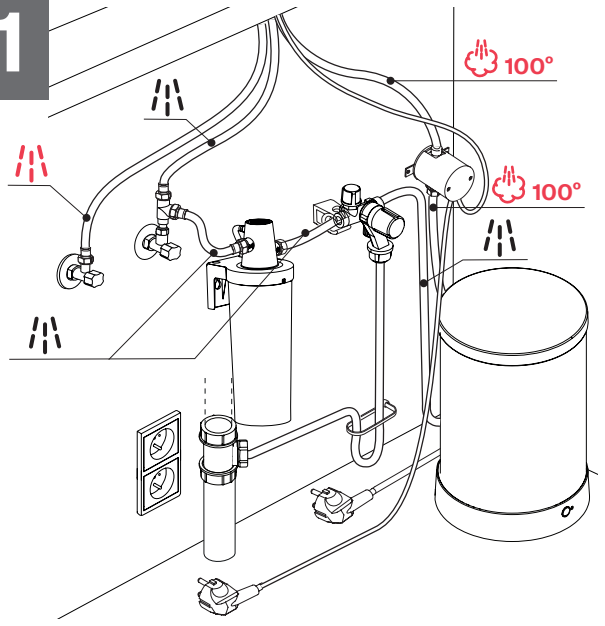

12

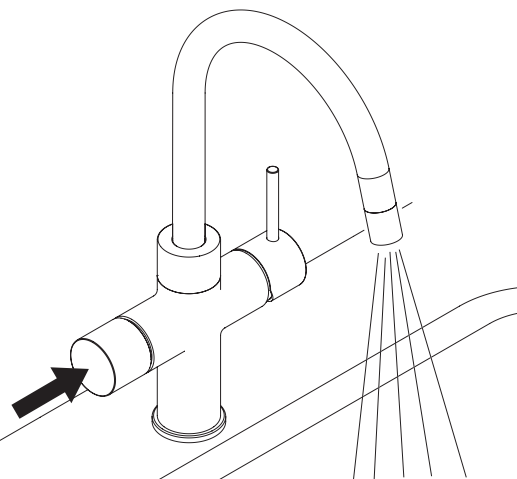
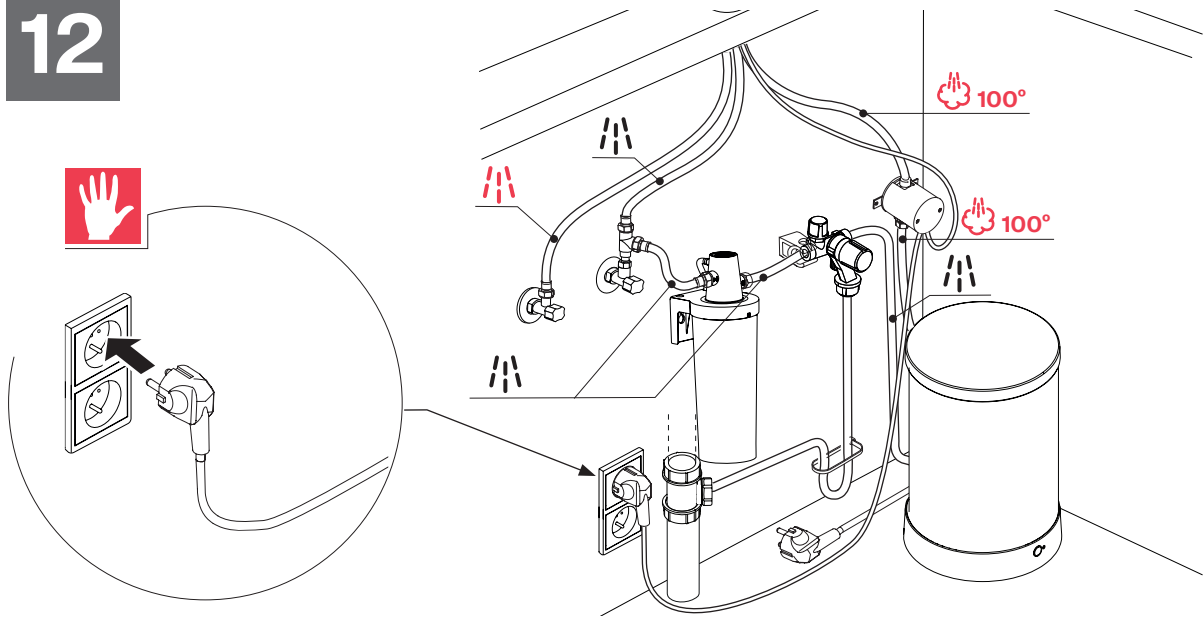

13

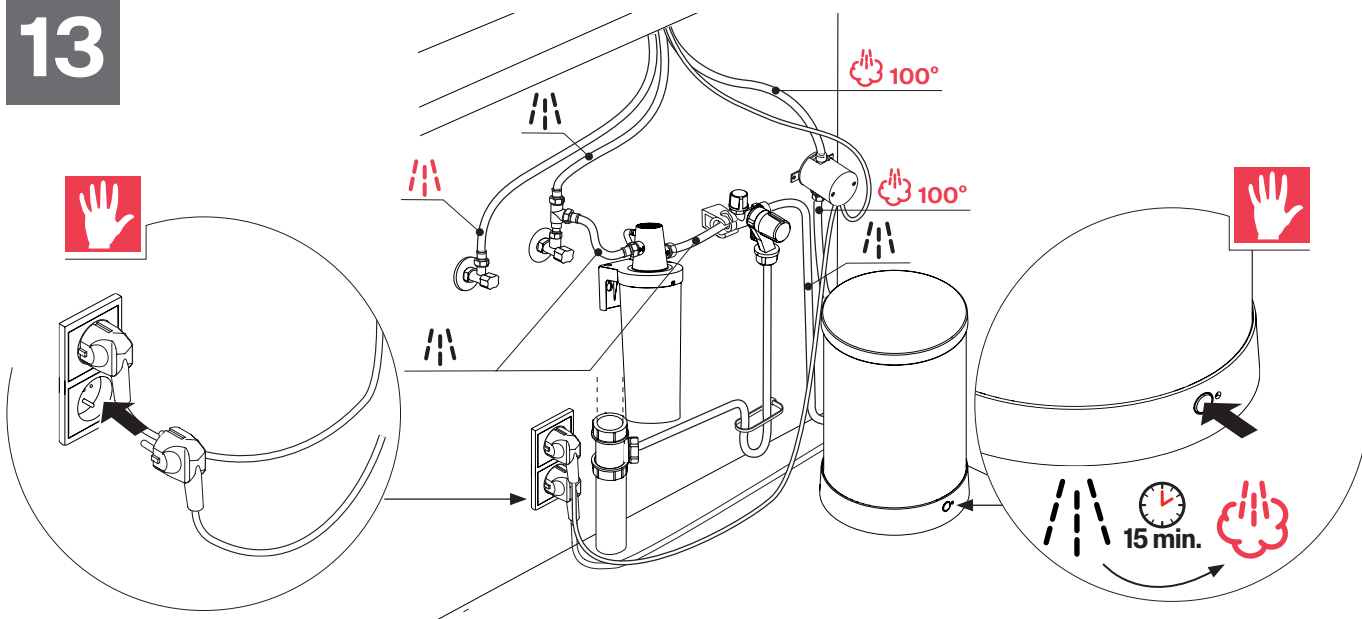



Niet inbegrepen

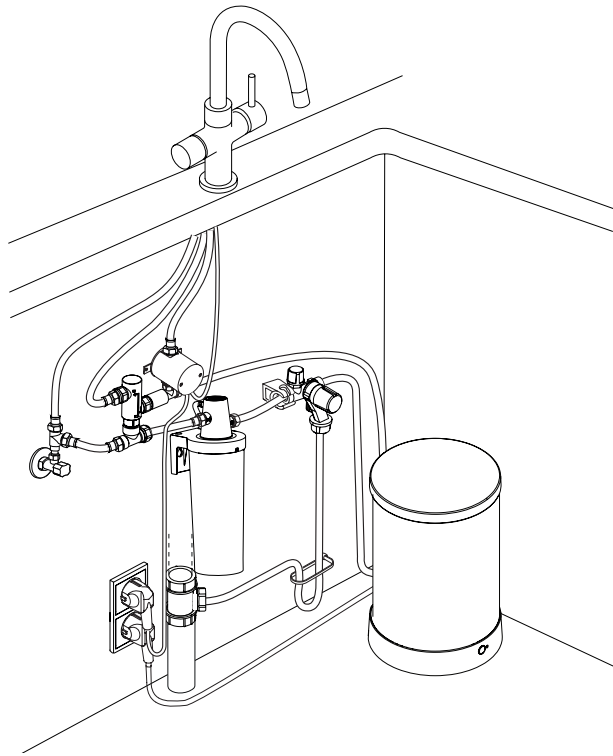
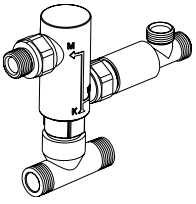

1

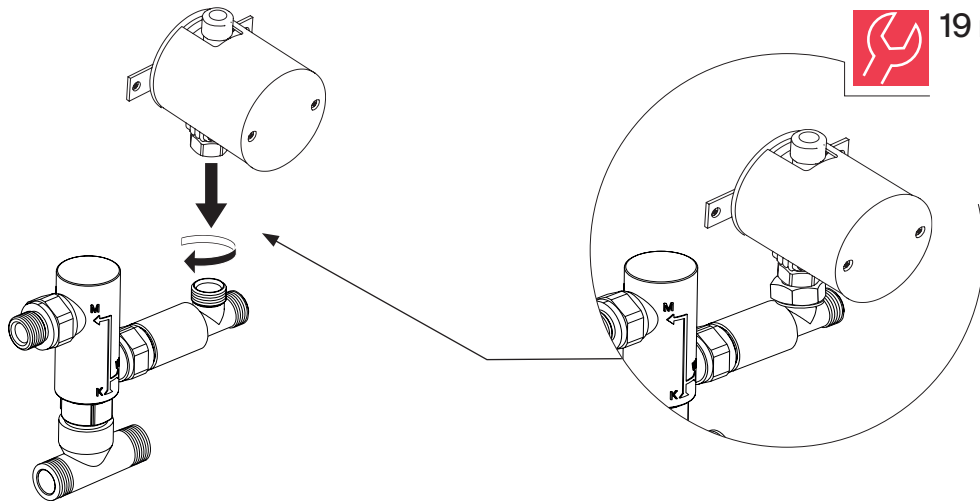

19 mm

2

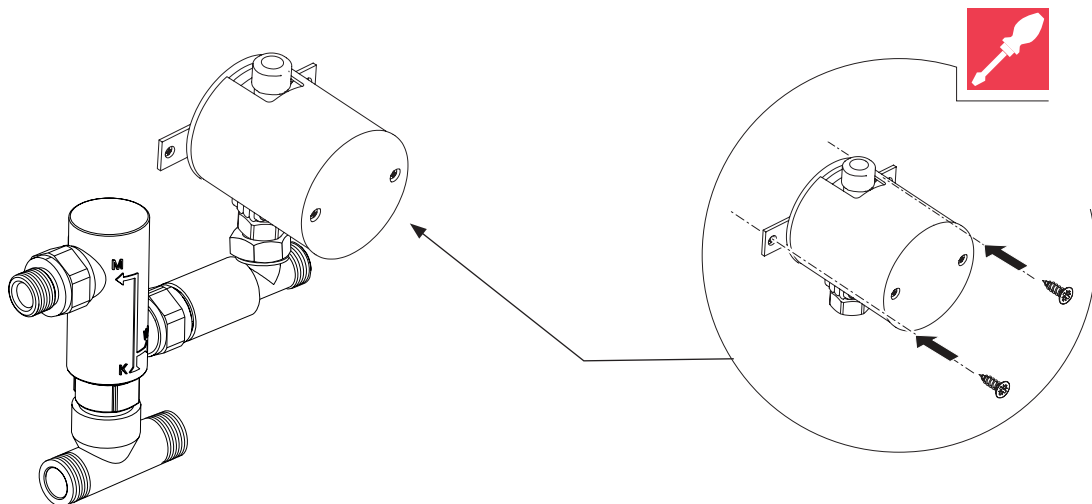

3

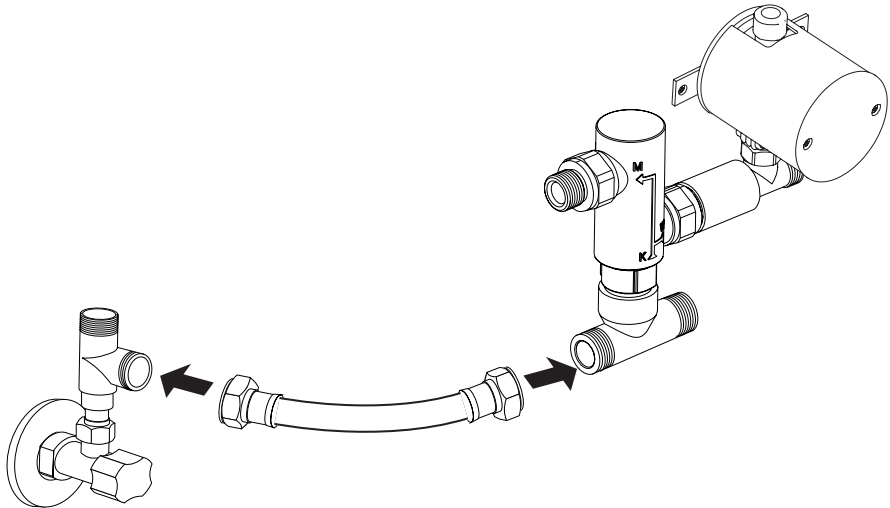

4

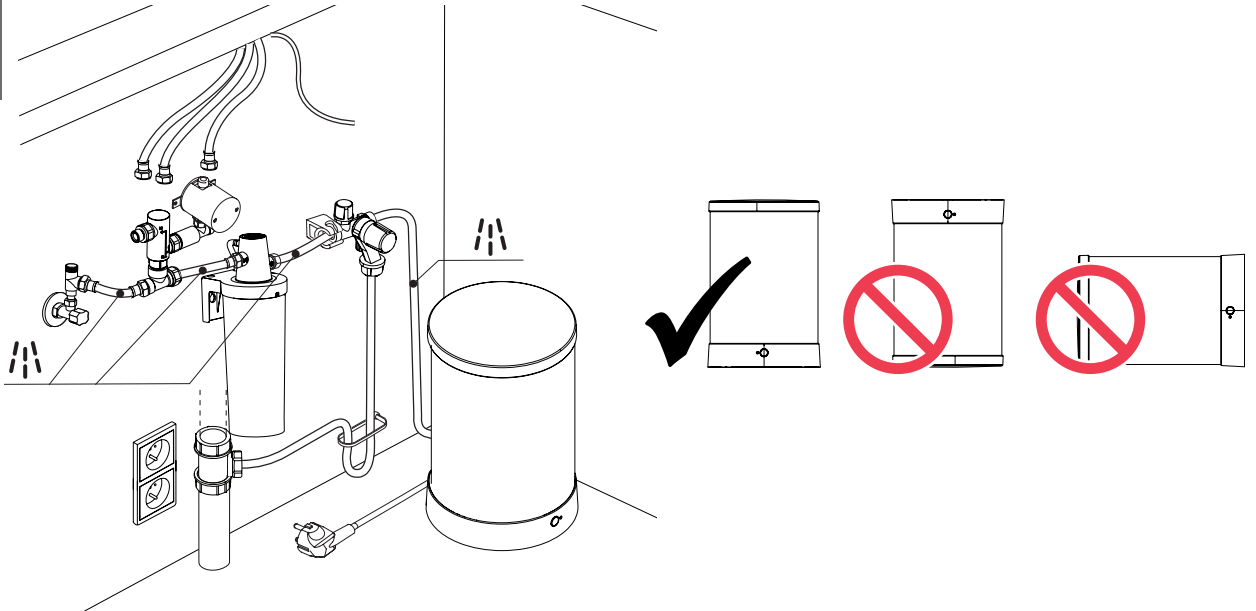

5

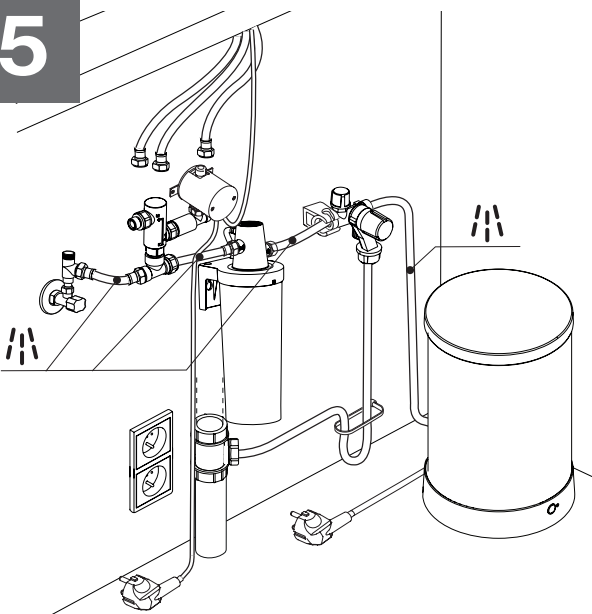

6

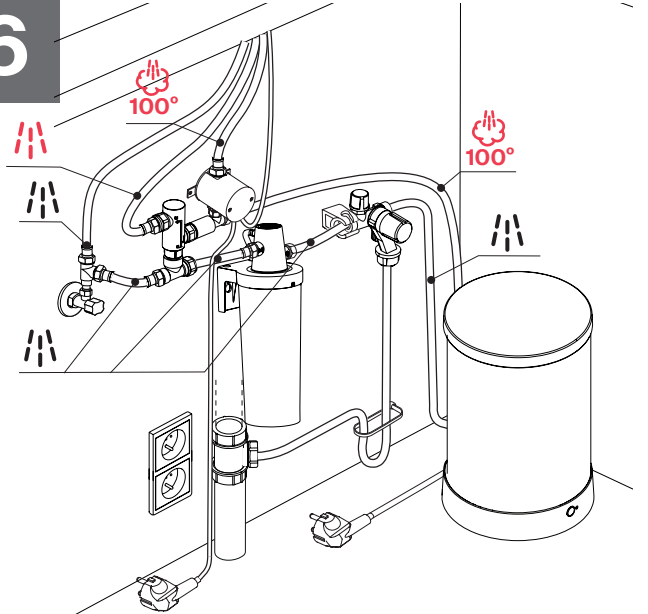

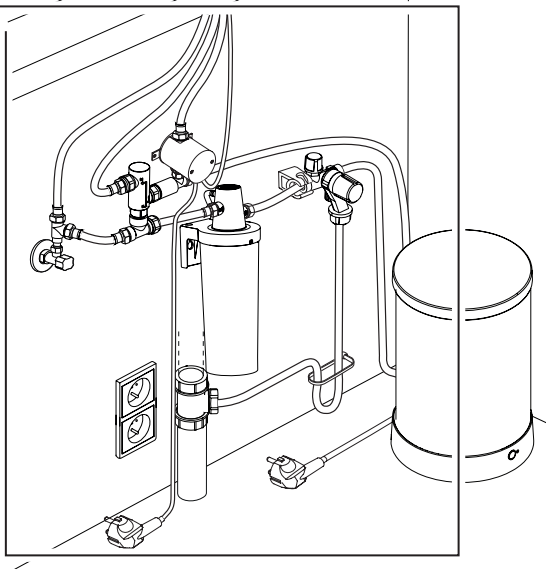
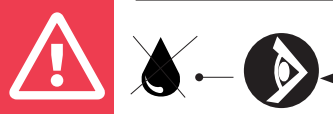
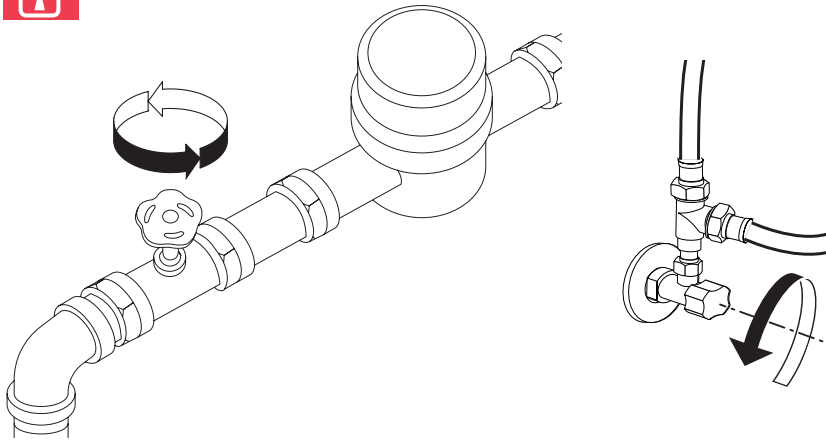

7

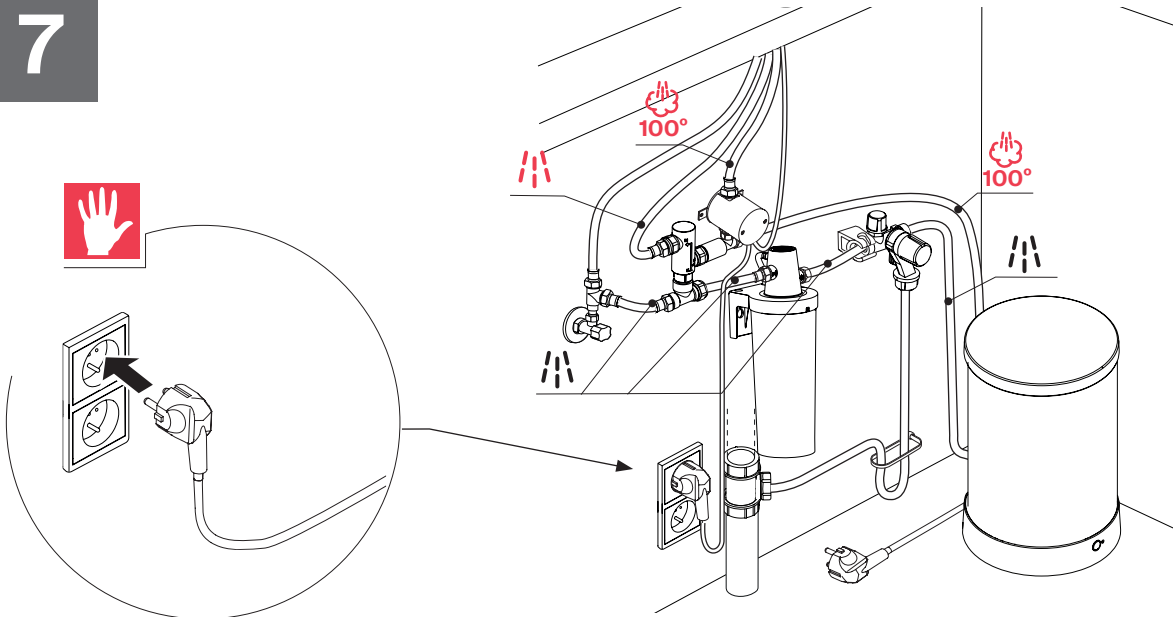

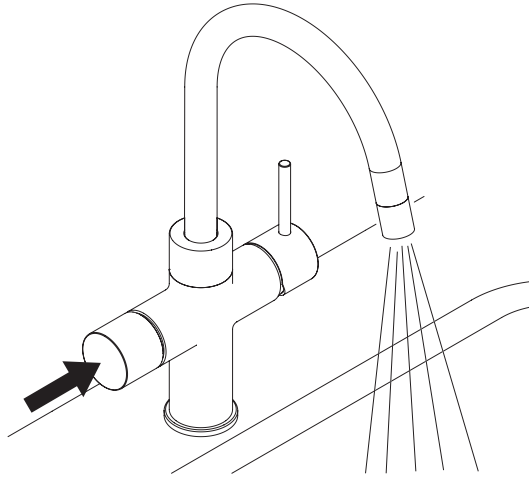
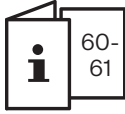

8

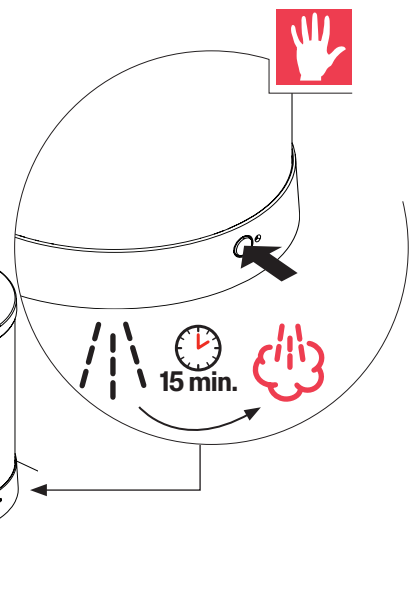
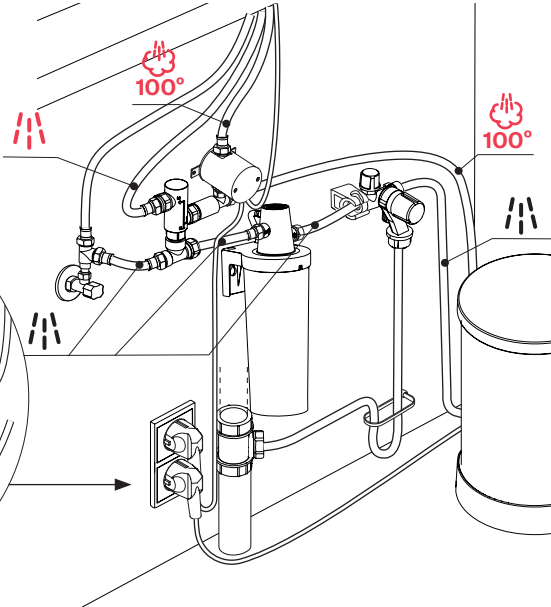
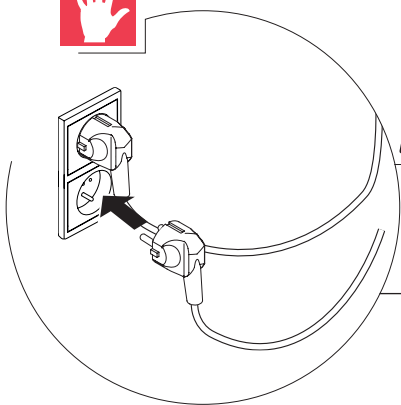



B

Niet inbegrepen

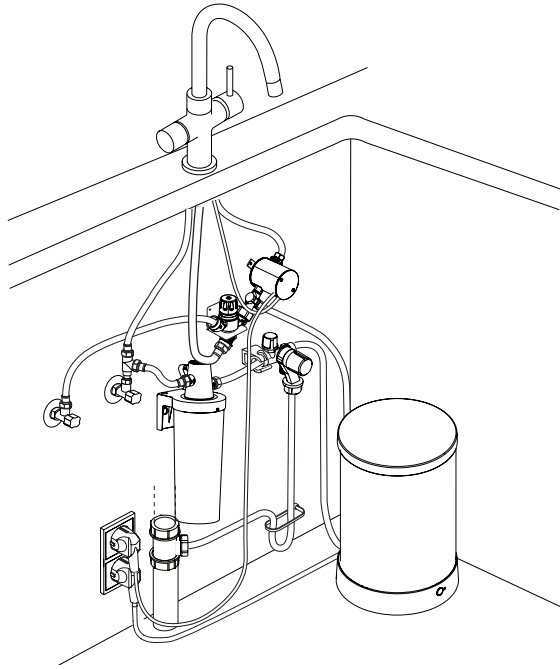
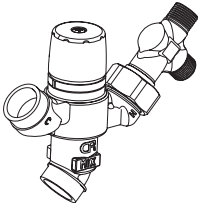

1

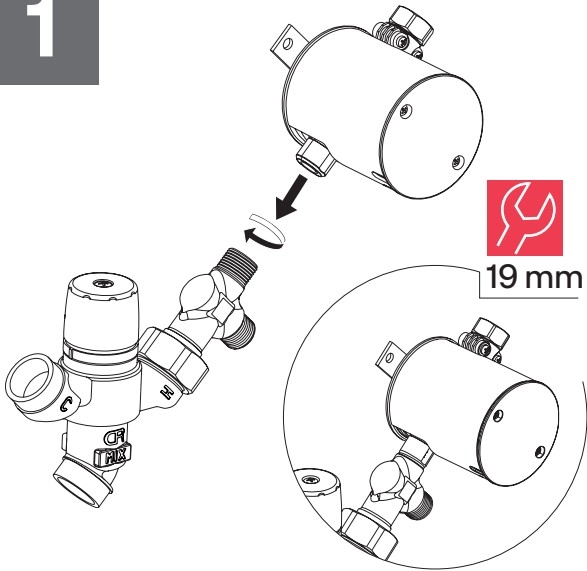

2

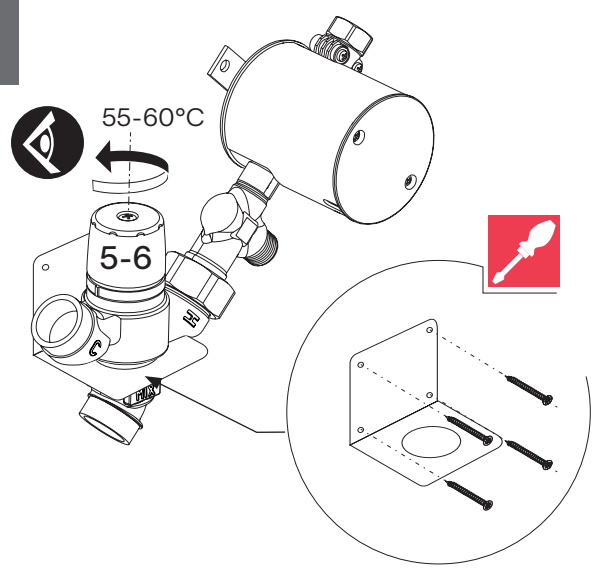

3

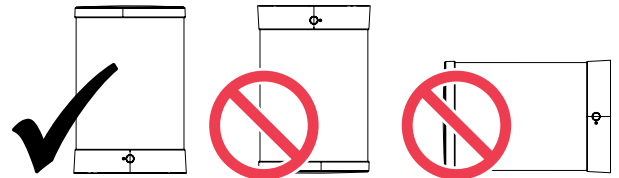
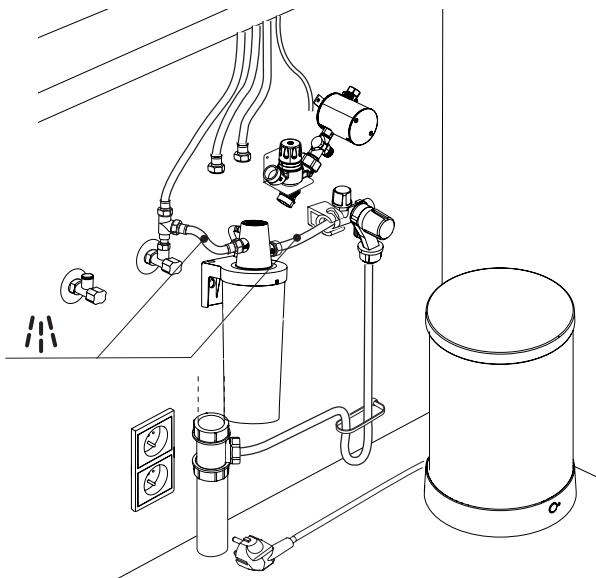

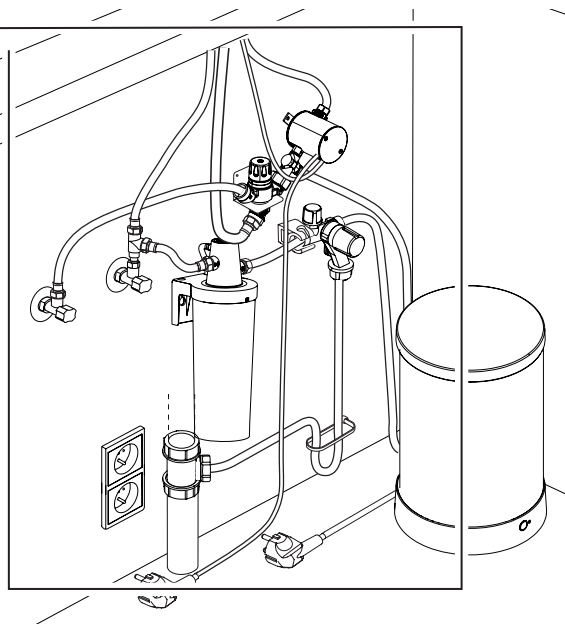
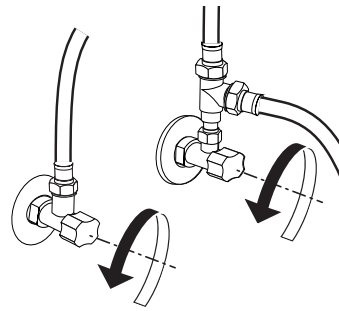
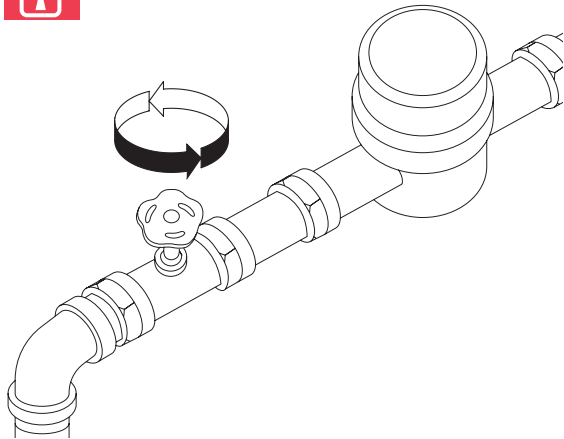
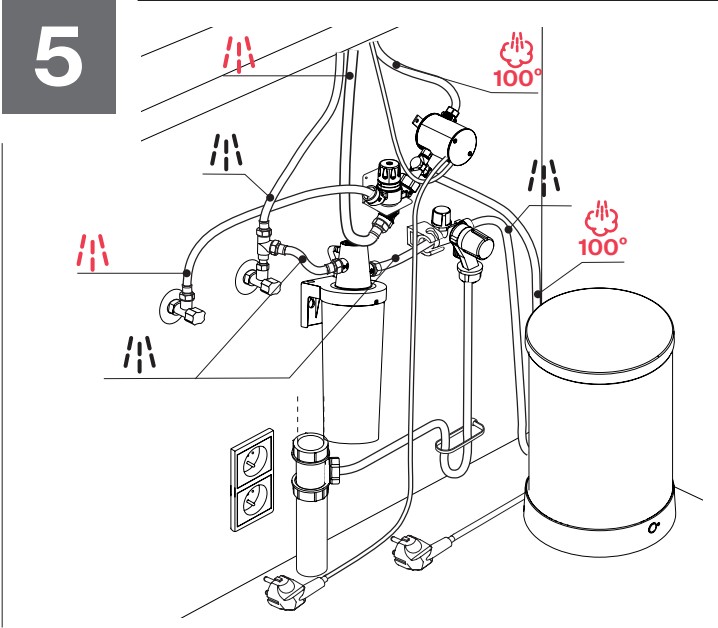
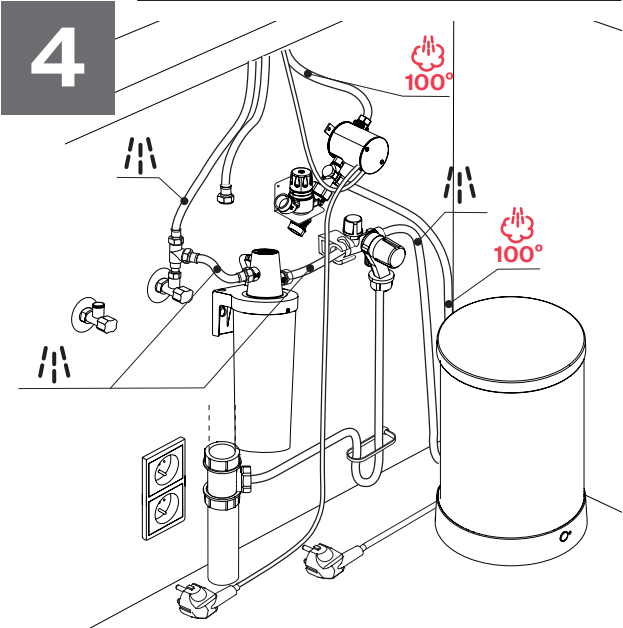

6

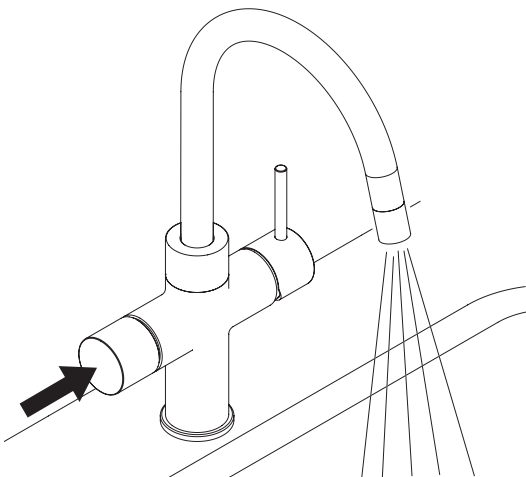
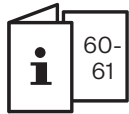
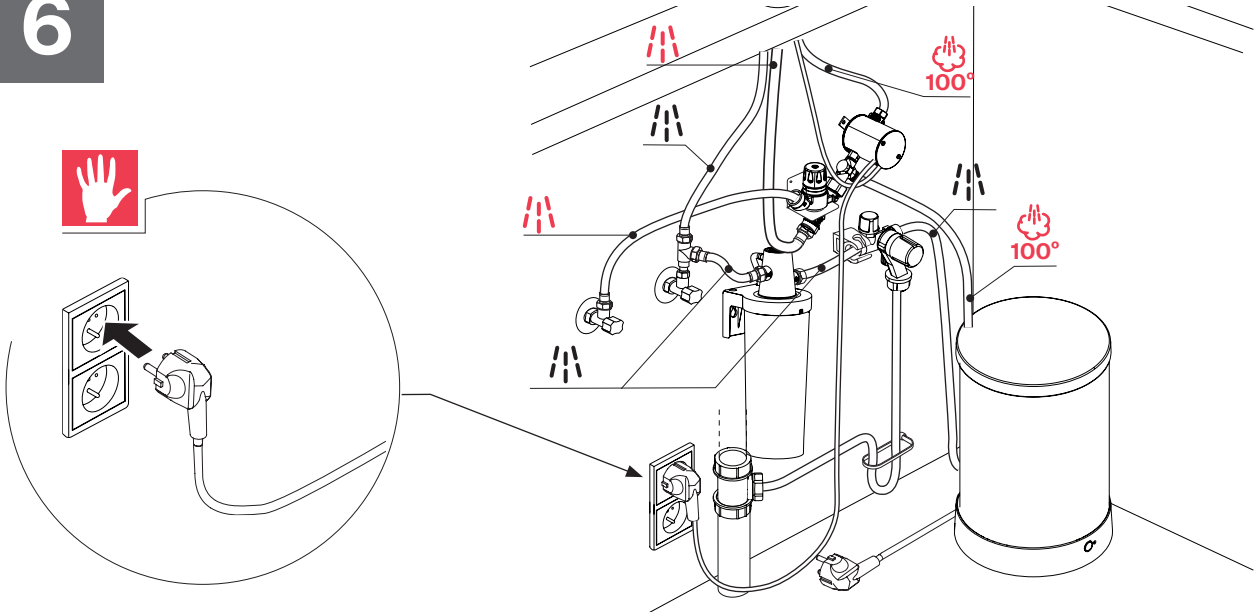

7

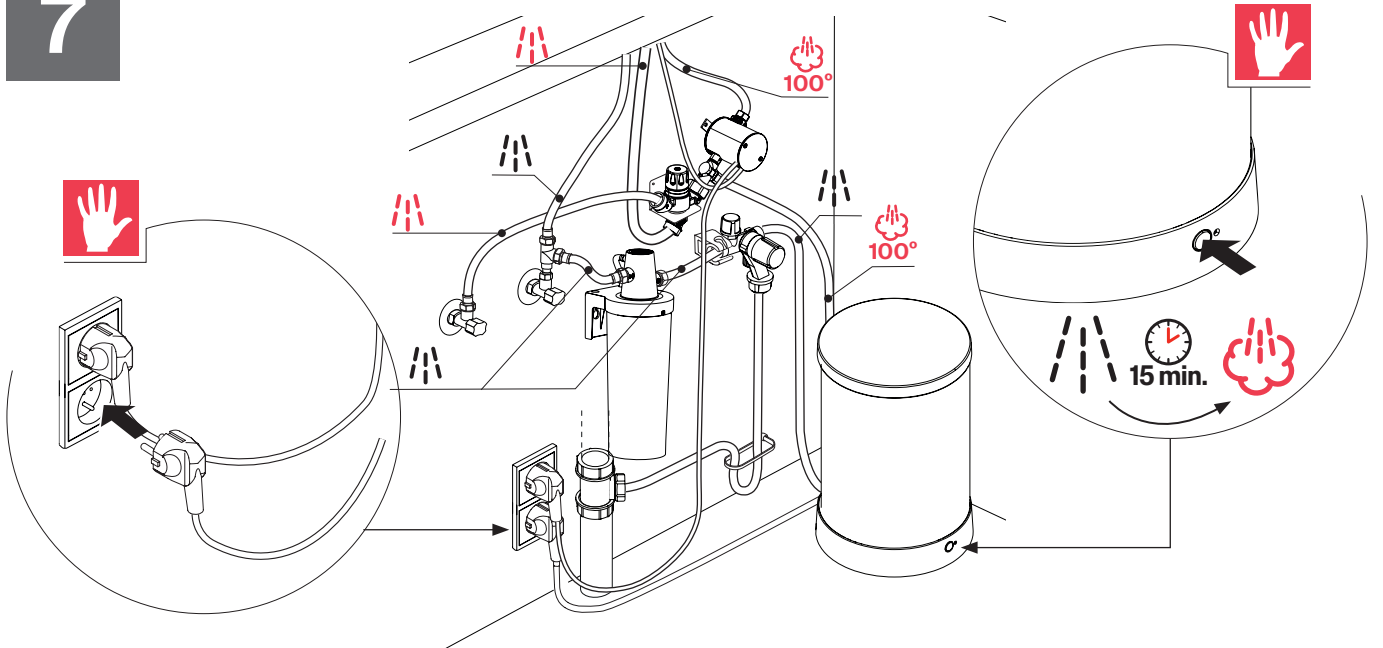

Bediening

Bediening van de boiler

- ▶ Door kort op de toets AAN/STAND-BY te drukken, kunt u de boiler van AAN naar STAND-BY schakelen.

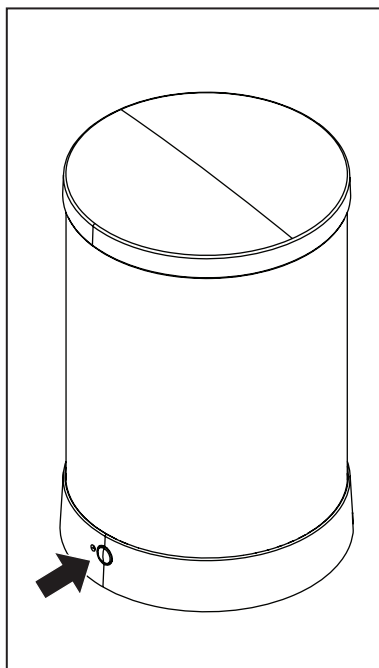

AAN:

- Boiler verwarmt continue totdat de 103 graden is bereikt.

UIT:

- De boiler is uitgeschakeld en verwarmt niet.

Als de boiler een week uitgeschakeld is geweest, raden wij aan om vóór gebruik de volgende procedure in acht te nemen:

- ▶ Zet de boiler aan. Wacht tot het boilerwater op temperatuur is.
- ▶ Open de kokendwaterkraan en spoel de kokendwaterleiding door totdat er koud water uit de kraan komt.

 **Let op:** controleer of het water tijdens het doorspoelen niet vernevelt.

- ▶ Verwarm nogmaals het boilerwater.

De boiler buiten bedrijf stellen

1. Verwijder de stekker van de boiler uit het stopcontact.
2. Draai de kokendwaterkraan open.
3. Wacht tot er koud water uit komt.
4. Draai de kokendwaterkraan dicht.
5. Sluit de stopkraan.
6. Draai de kokendwaterkraan open.
7. Wacht tot er geen water meer uit komt.
8. Draai de kokendwaterkraan dicht.
9. Koppel de slangen los van de boiler.
10. Verwijder de boiler.
11. Voer het water uit de slangen en de boiler af in de gootsteen.

De boiler buiten gebruik stellen

Als u verwacht langere tijd geen kokend water nodig te hebben, bijvoorbeeld tijdens vakanties, kunt u de boiler (tijdelijk) uitschakelen:

- ▶ Gebruik de STANDBY-modus van de boiler of verwijder de stekker uit het stopcontact om te voorkomen dat de boiler verwarmt.

Voor het eerst inschakelen



Controleer of de boiler met water is gevuld!

Boiler

1. Bedien de mengkraan en spoel 1 minuut lang met warm water door (afb. 1).
2. Open de elektronische knop van de kraan. De boiler wordt gevuld met water (afb. 2). Er komt lucht uit de kraan. Spoel het systeem goed door: als er een gelijkmatige laminaire straal uit de kraan komt, is het systeem goed doorgespoeld.
3. Schakel de boiler in (afb. 3).

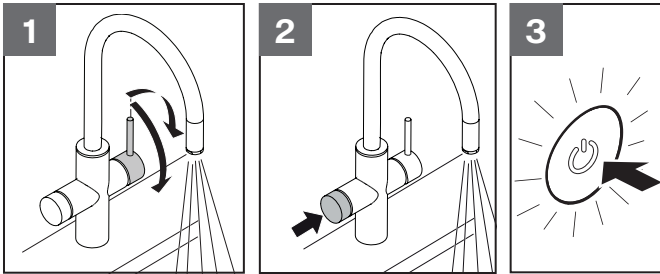

4. Controleer de installatie na de inbedrijfstelling op lekkages.

Het water bereikt na ongeveer 15 minuten de kooktemperatuur.



Waarschuwing: als er tijdens het verwarmen na 10 minuten geen expansiewater is ontsnapt:

schakel de stroomtoevoer onmiddellijk uit en draai de kokendwaterkraan open om de waterdruk te ontlasten.

- ▶ De boiler is opgewarmd als de toets ON/STANDBY continu rood brandt.

5. Om de tank te reinigen moet de kokendwaterkraan geopend worden totdat er koud water uit komt.

Kraanbediening

Bediening van de menghendel

- ▶ Kies heet water (afb. 4).

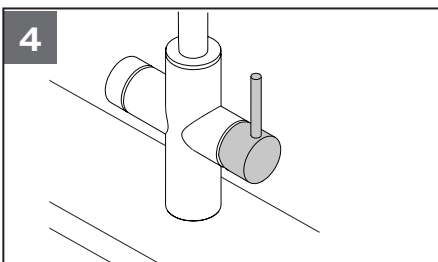

- ▶ Kies koud water (afb. 5).

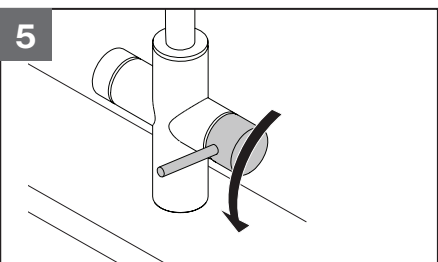

- ▶ Draai de mengkraan open (afb. 6).

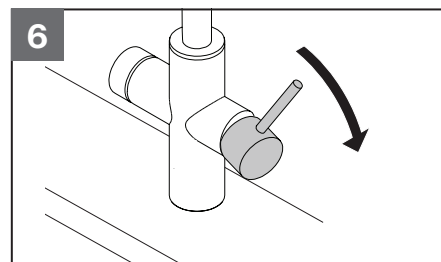

Bediening van de elektronische knop

- ▶ Activeer de kraan: 1x kort indrukken (afb. 7).

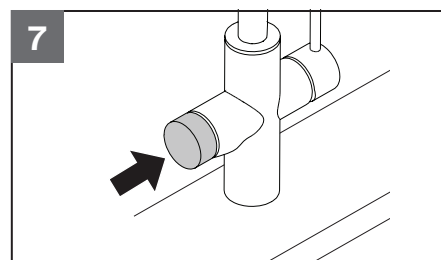

- ▶ indrukken en naar achteren draaien (om de keuze kokend water te activeren (afb. 8).

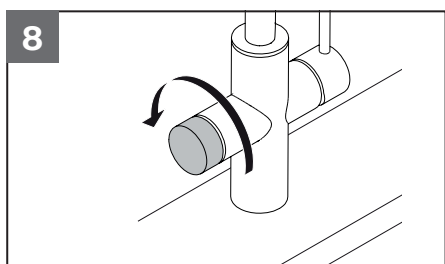

- ▶ Kokend water: houdt de keuzeknop ingedrukt (afb. 9). Deactiveren: laat de knop los.

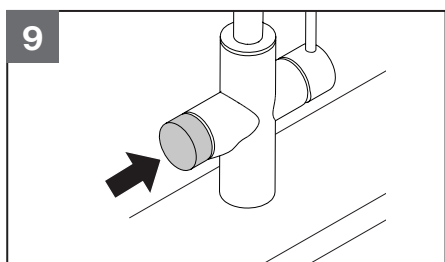

- ▶ Korte vulmodus: 2x kort indrukken (afb. 10). Stopt automatisch. Deactiveren: 1x kort indrukken.

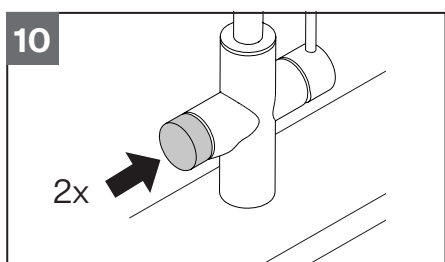

- ▶ Lange vulmodus: 3x kort indrukken (afb. 11). Stopt automatisch. Deactiveren: 1x kort indrukken.

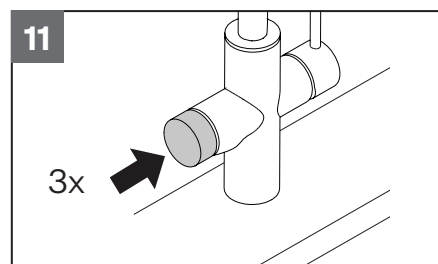

- ▶ Houd het te vullen voorwerp dicht bij de kraan, zodat het de uitstroomopening van de kraan omsluit. Zo voorkomt u dat het (hete) water gaat spetteren.
- ▶ Voor een optimaal resultaat bij het zetten van koffie of thee moet u ongeveer 1 kopje water laten doorlopen voordat u de pot vult. Op deze manier verdwijnen de luchtbelletjes uit het water, zodat er zich geen schuimlaagje op de thee vormt.

Vulmodus

- ▶ 2x kort indrukken om de pot te vullen. Pot vullen: kokend water (rood) = 30 sec. stromen.
- ▶ 3x kort indrukken om de pot te vullen. Pot vullen: kokend water (rood) = 60 sec. stromen

Led-indicatie status elektronische knop

Led-kleur	Led-activiteit	Werking
Rood	Constant	Kokend water

Filter installeren / vervangen

1. Houd de knop (in de neutrale positie) gedurende 10 seconden ingedrukt.
2. Draai de elektronische knop naar achteren om de juiste kleur te selecteren houdt u de knop ingedrukt gedurende 2 seconden. De LED knippert 3 keer ter bevestiging en ga terug naar de neutrale positie.

De LED in de neutrale stand herinnert u er 1 maand vooraf dat het filter moet worden vervangen. De LED in de neutrale stand schakelt van wit naar oranje.

Als het filter de vervaldatum heeft bereikt, begint de oranje LED pulseren totdat het filter is vervangen.

Na de filtervervangning herhaalt u stap 1 en 2 handeling.

Als u uw systeem heeft geregistreerd, ontvangt u een herinnering via e-mail.

! Het is verplicht om een Franke filter te gebruiken teneinde het product tegen kalkaanslag te beschermen. Het is verplicht om het filter te vervangen op basis van de waterhardheidstabel.

Waterhardheid	Led-kleur
<10°dh	lichtblauw
10-15°dh	geel
15-20°dh	lichtgroen
>20°dh	paars

Selectie van lichtsterkte elektronische knop

Als de kraan 60 seconden niet wordt gebruikt schakelt deze automatisch over naar de slaapstand, 50% led-intensiteit.

Om de instelling van de slaapmodus te wijzigen, moet u de onderstaande instructie volgen.

1. Activeer de kraan door eenmaal op de elektronische knop te drukken.
2. Druk 5 keer op de elektronische knop
3. De LED begint te knipperen.
4. Draai de knop naar de gewenste stand door de knop naar voren of naar achteren te draaien.
 - 1: 50% intensiteit, standaard
 - 2: 10% intensiteit
 - 3: Volledig uitgeschakeld
5. Druk na de selectie 2 seconden op de elektronische knop om te bevestigen. De kraan knippert 3 keer ter bevestiging.

Meldingen en storingen

Boilermeldingen

Led-kleur	Led-activiteit	Beschrijving
Blauw	Knipperend	Er zit geen water in de boiler.
Blauw	Continu	Zelfcontrole inbedrijfstelling/systeem.
Oranje	Knipperend	Systeemstoring; neem contact op met de servicedienst van Franke.
Rood	Knipperend	Boiler warmt op.
Rood	Continu	Boiler is volledig opgewarmd.

Meldingen kraan

Led-kleur	Led-activiteit	Werking	Beschrijving
Rood	Continu	Kokend water	Er kan voor kokend water worden gekozen.
Rood	Roterend	Keuze van kokend water is bezig.	Keuze van kokend water is bezig.
Oranje	Continu	Filter	Filter is bijna leeg en moet binnen 1 maand worden vervangen.
Oranje	Knipperend	Filter	Filter is leeg en moet direct worden vervangen.

Probleemoplossing

Elektronische knop reageert niet

Oorzaak	Oplossing
Softwareprobleem.	Koppel de stroomtoevoer minstens 10 seconden los.
De kabelaanluiting van de kraan is niet correct aangesloten.	Sluit de kabelaanluiting correct aan.
Het stopcontact is niet op de stroom aangesloten.	Controleer de elektriciteitstoevoer. De elektrische groep is uitgevallen door een te hoge belasting. De boiler kan niet worden aangesloten op dezelfde elektriciteitsgroep als een vaatwasser. Franke adviseert de Power-combischakelaar 112.0561.116
De kabel of de aansluiting van de kraan is beschadigd of defect.	Neem contact op met Franke.

Waterlekkage

Oorzaak	Oplossing
Aansluiting lekt	Controleer koppelstuk(ken) en draai zo nodig opnieuw vast.
Slang(en) lekt/lekken	Controleer de slang(en) en vervang de lekkende slang(en).
Boiler lekt	Verwijder de stekker van de boiler uit het stopcontact. Sluit de watertoevoer af. Neem contact op met Franke.
Kraan lekt	Sluit de watertoevoer af. Neem contact op met Franke.

Kraan levert geen water

Oorzaak	Oplossing
Slang(en) is/zijn geknikt.	Controleer de slang(en) en vervang de geknikte slang(en).
De hoofdwaterraan is gesloten.	Open de hoofdwaterraan.
De stopkraan in het keukenkastje is gesloten.	Open de stopkraan.

Kraan levert geen kokend water

Oorzaak	Oplossing
Slang(en) is/zijn geknikt.	Controleer de slang(en) en vervang de geknikte slang(en).
Overdrukventiel is dicht.	Open deze door aan de knop te draaien.
Filter niet of niet correct geïnstalleerd.	Controleer of het filter goed vastzit.
Elektronische knop is niet verbonden met stopcontact.	Controleer of de elektrische aansluitingen zijn aangesloten.

Kraan levert geen warm water

Oorzaak	Oplossing
Slang(en) is/zijn geknikt.	Controleer de slang(en) en vervang de geknikte slang(en).
Boiler werkt niet.	Zie de tabel "Het water uit de kraan kookt niet".
Het warmwatertoestel werkt niet.	Raadpleeg de handleiding van uw warmwatertoestel, warmwaterondersteuning of bypass.

Het water uit de kraan kookt niet

Oorzaak	Oplossing
De stekker van de boiler zit niet in een stopcontact.	Steek de stekker in een geaard stopcontact.
Het stopcontact is niet op de stroom aangesloten.	Controleer de elektriciteitstoevoer. Het elektrische circuit is uitgevallen door een te hoge belasting. De boiler kan niet worden aangesloten op hetzelfde elektrische circuit als een vaatwasser. Franke adviseert de Power-combischakelaar 112.0561.116.
De boiler is UIT (wachtmodus).	Zet de boiler AAN.
De boiler is niet volledig opgewarmd.	Wacht tot de boiler is opgewarmd.
De boiler is defect.	Neem contact op met Franke.

De boiler veroorzaakt kortsluiting

Oorzaak	Oplossing
Er is kortsluiting in de elektrische bedrading of in het verwarmingselement van de boiler.	Verwijder de stekker van de boiler uit het stopcontact. Neem contact op met Franke.
Geen water in de boiler.	Vul de boiler met water.

Onderhoud

Algemeen onderhoud

- ▶ Reinig de kraan alleen met kraanreiniger van Franke.
- ▶ Gebruik geen reinigingsmiddelen die een oplosmiddel of zuur bevatten, zoals kalkverwijderaars, huishoudazijn of reinigingsmiddelen met azijnzuur. Deze bestanddelen beschadigen het oppervlak. De kraan wordt mat en krijgt krassen.
- ▶ Kalkaanslag kan worden voorkomen door de kraan na gebruik af te drogen.
- ▶ Mocht er toch kalkaanslag optreden, dan moet deze met een reinigingsmiddel op basis van citroenzuur worden verwijderd.
- ▶ Gebruik voor onderhoud of reparatie altijd originele onderdelen van Franke. Dit garandeert de veiligheid en de goede werking van het product en waarborgt eventuele garantieclaims.
- ▶ Vervanging of reparatie van onderdelen mag alleen door de servicedienst van Franke worden uitgevoerd.

Filter vervangen

- ▶ Draai het filter naar rechts om het uit de filterkop te verwijderen.
- ▶ Draai het nieuwe filter naar links om het te installeren.
- ▶ Reset de filterinstelling zie pagina 61 (filter installeren).
- ▶ De filterkop heeft een ingebouwde automatische waterafsluitklep. Om het filter te vervangen hoeft de watertoevoer niet te worden afgesloten.

Ontkalken van het zeefje

- ▶ **Gebruik altijd een ontkalkingsmiddel op basis van citroenzuur.** Andere middelen beschadigen het materiaal!
- ▶ Het los- en vastdraaien kan worden vergemakkelijkt door een elastiek om de huls van de kraanbeluchter te wikkelen. Zorg ervoor dat de huls van de kraanbeluchter niet door het gebruik van gereedschap wordt beschadigd.
- ▶ In de loop der tijd ontstaat er op en naast de kraanbeluchter kalkaanslag.
- ▶ Schroef de huls van de kraanbeluchter los (afb. 12).
- ▶ Reinig de kraanbeluchter met een geschikt ontkalkingsmiddel (afb. 13).
- ▶ Plaats de kraanbeluchter in de huls (afb. 14).
- ▶ Plaats de pakking op de kraanbeluchter (afb. 15) en draai de huls handvast aan (afb. 16).

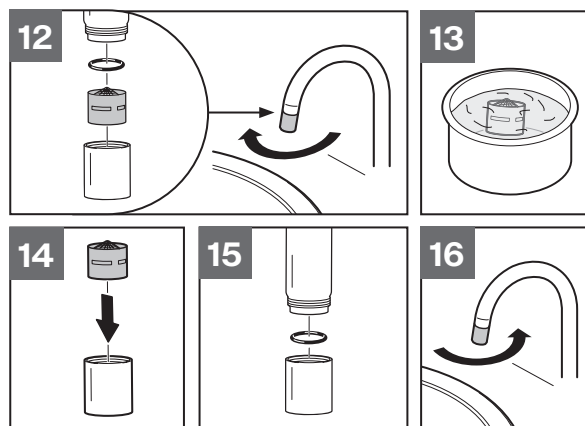

Afvalverwijdering



Het symbool op het product of op de verpakking geeft aan dat het toestel niet bij het huisvuil mag worden weggegooid.

Door het toestel op de juiste manier weg te gooien, draagt u bij tot het voorkomen van schadelijke gevolgen voor het milieu en de gezondheid.

Meer informatie over het recyclen van het toestel kunt u opvragen bij de bevoegde instantie, de plaatselijke afvalverwerkingsdienst of de verkoper van het toestel.

Breng het weg te gooien toestel naar een gespecialiseerd inzamelpunt voor elektronische en elektrische apparaten.

In overeenstemming met het artikel van wetsbesluit nr. 15 van 25 juli, implementatie van richtlijn 2002/96/EG betreffende de vermindering van het gebruik van gevaarlijke stoffen die worden gebruikt in elektrische en elektronische apparaten, en in afvalverwijdering.

Het symbool van de doorgestreepte vuilnisbak op het toestel geeft aan dat het product aan het einde van zijn levensduur niet als huisvuil mag worden weggegooid.

Het toestel moet dus aan het einde van zijn levensduur naar een geschikt recyclingcentrum voor elektronisch en elektrotechnisch afval worden gebracht of bij de aankoop van een nieuw toestel van een gelijkwaardig type bij de dealer worden ingeleverd.

Een correcte gescheiden afvalinzameling van het afgedankte toestel voor latere recycling, verwerking en milieuvriendelijke afvalverwijdering helpt een mogelijk negatieve impact op het milieu en de gezondheid te voorkomen en vergemakkelijkt de recycling van de materialen die bij de constructie van het toestel zijn gebruikt.



Franke S.p.A.
Via Pignolini 2, 37019 Peschiera del Garda, ITALIA
Tel 045 6449311
www.franke.it

EU DECLARATION OF CONFORMITY

We, Franke spa addressed in Via Pignolini 2, 37019, Peschiera del Garda, ITALY, declare under our sole responsibility that the product:

FRANKE CODE:	MODEL DESCRIPTION:
119.0698.122	Tap Maris Water Hub MFT elec J-spout SS

to which this declaration relates is in conformity with the following directives and standards:

Directives:

- 2014/30/EU “EMC Directive”
- 2011/65/EU “Restriction of the use of certain hazardous substances in electrical and electronic equipment (RoHS)”
- 2015/863/EU “Amending Annex II to Directive 2011/65/EU”

Standards:

- EN IEC 61000-6-1:2019
- EN IEC 61000-6-2:2019
- EN 61000-6-3:2021
- EN IEC 61000-6-4:2019
- EN 55014-1:2021
- EN 55014-2:2021
- EN IEC 63000:2018

Place and date: Peschiera del Garda, 08/05/2023

Franke S.p.A.
Chief Executive Officer
Barbara Borra



EU DECLARATION OF CONFORMITY

Franke S.p.A.
Via Pignolini 2, 37019 Peschiera del Garda, ITALIA
Tel 045 6449311
www.franke.it

We, Franke spa addressed in Via Pignolini 2, 37019, Peschiera del Garda, ITALY, declare under our sole responsibility that the product:

FRANKE CODE: 133.0702.321

MODEL DESCRIPTION: RIC Maris Water Hub Hydraulic Box electr

to which this declaration relates is in conformity with the following directives and standards:

Directives:

- 2014/35/EU “Low Voltage Directive”
- 2014/30/EU “EMC Directive”
- 2011/65/EU “Restriction of the use of certain hazardous substances in electrical and electronic equipment (RoHS)”
- 2015/863/EU “Amending Annex II to Directive 2011/65/EU”
- 2009/125/EG – Erp Directive (ÖkoDesign)

Standards:

- EN IEC 62368-1:2020 + A11:2020
- EN IEC 61000-3-2:2019 + A1:2021
- EN 61000-3-3:2013 + A1:2019 +A2:2021 + A2:2021/AC:2022
- EN 55032:2015 + AC:2016 + A11:2020 + A1:2020
- EN 55035:2017 + A11:2020
- EN IEC 61000-6-1:2019
- EN IEC 61000-6-2:2019
- EN 61000-6-3:2021
- EN IEC 61000-6-4:2019
- EN 55014-1:2021
- EN 55014-2:2021
- EN IEC 63000:2018

Place and date: Peschiera del Garda, 08/05/2023

Franke S.p.A.
Chief Executive Officer
Barbara Borra



Franke S.p.A.
Via Pignolini 2, 37019 Peschiera del Garda, ITALIA
Tel 045 6449311
www.franke.it

EU DECLARATION OF CONFORMITY

We, Franke spa addressed in Via Pignolini 2 37019 Peschiera del Garda ITALY, declare under our sole responsibility that the product:

FRANKE CODE: 119.0697.146
MODEL DESCRIPTION: MARIS BOILER 4L

to which this declaration relates is in conformity with the following directives and standards:

Directives:

- 2014/35/EU “Low Voltage Directive”
- 2014/30/EU “EMC Directive”
- 2017/1369/EU “Framework for energy labelling”
- 2011/65/EU “Restriction of the use of certain hazardous substances in electrical and electronic equipment (RoHS)”
- 2015/863/EU “Amending Annex II to Directive 2011/65/EU”
- 2014/68/EU “Pressure equipment”

Standards:

- EN 60335-1:2012 + AC:2014 + A11:2014 + A13:2017 + A1:2019 + A2:2019 + A14:2019 + A15:2021
- EN 60335-2-21:2021 + A1:2021
- EN 60529:1991 + A1:2000 + A2:2013 + AC:2019
- EN IEC 61000-3-2:2019 + A1:2021
- EN 61000-3-3:2013 + A1:2019 + A2:2021
- EN IEC 55014-1:2021
- EN IEC 55014-2:2021
- EN 50440:2015 + A1:2020
- EN IEC 63000:2018

Place and date: Peschiera del Garda, 03/04/2023

Franke S.p.A.
Chief Executive Officer
Barbara Borra

